

Errata

Title & Document Type: 5246L Electronic Counter Operating and Service Manual

Manual Part Number: 05246-90001

Revision Date: August 1968

About this Manual

We've added this manual to the Agilent website in an effort to help you support your product. This manual provides the best information we could find. It may be incomplete or contain dated information, and the scan quality may not be ideal. If we find a better copy in the future, we will add it to the Agilent website.

HP References in this Manual

This manual may contain references to HP or Hewlett-Packard. Please note that Hewlett-Packard's former test and measurement, life sciences, and chemical analysis businesses are now part of Agilent Technologies. The HP XXXX referred to in this document is now the Agilent XXXX. For example, model number HP8648A is now model number Agilent 8648A. We have made no changes to this manual copy.

Support for Your Product

Agilent no longer sells or supports this product. You will find any other available product information on the Agilent Test & Measurement website:

www.agilent.com

Search for the model number of this product, and the resulting product page will guide you to any available information. Our service centers may be able to perform calibration if no repair parts are needed, but no other support from Agilent is available.

OPERATING MANUAL

ELECTRONIC COUNTER 5246L

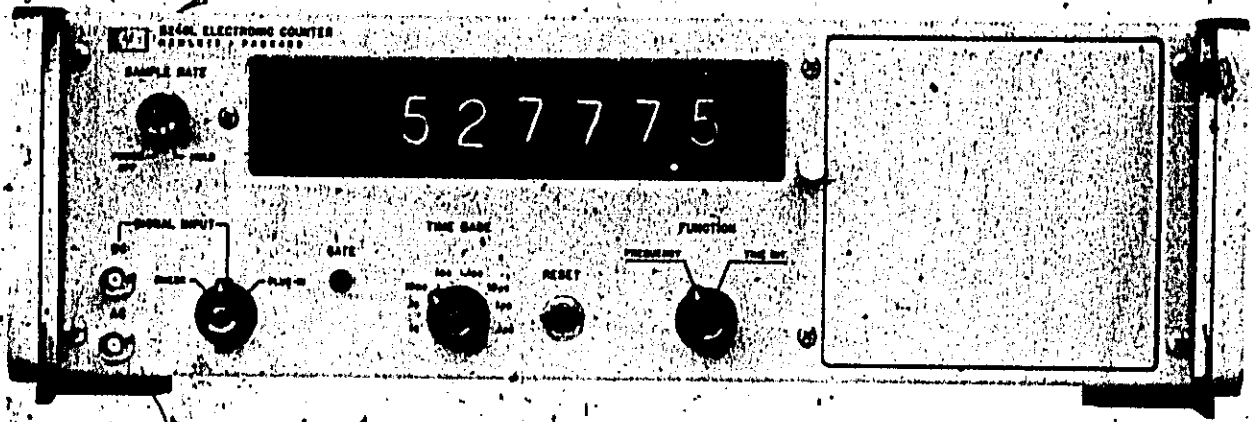

HEWLETT  PACKARD

CERTIFICATION

The Hewlett-Packard Company certifies that this instrument was thoroughly tested and inspected and found to meet its published specifications when it was shipped from the factory. The Hewlett-Packard Company further certifies that its calibration measurements are traceable to the U.S. National Bureau of Standards to the extent allowed by the Bureau's calibration facility.

WARRANTY AND ASSISTANCE

All Hewlett-Packard products are warranted against defects in materials and workmanship. This warranty applies for one year from the date of delivery, or, in the case of certain major components listed in the operating manual, for the specified period. We will repair or replace products which prove to be defective during the warranty period provided they are returned to Hewlett-Packard. No other warranty is expressed or implied. We are not liable for consequential damages.

Service contracts or customer assistance agreements are available for Hewlett-Packard products that require maintenance and repair on-site.

For any assistance, contact your nearest Hewlett-Packard Sales and Service Office. Addresses are provided at the back of this manual.

ELECTRONIC COUNTER

5246L

ALL SERIALS

The 5246L Operating Manual applies to all HP Model 5246L Electronic Counters.

This is an Operating Manual only, Adjustment and Troubleshooting information is provided in a separate Service Manual.

Copyright © HEWLETT-PACKARD COMPANY 1967
1501 PAGE MILL ROAD, PALO ALTO, CALIFORNIA, U.S.A.

02364-2

Printed: AUG-1968

HEWLETT  PACKARD

MANUAL CONTENT

This is an Operating Manual only. Service instructions are outlined in a separate Service Manual. This Operating Manual is supplied to help you make the best use of your HP Model 5246L Electronic Counter. Four sections of information are included as follows:

Section I is an introduction to the Counter. This includes a table of technical specifications.

Section II contains information for installation and shipment.

Section III explains operation of the Counter and all available plug-ins.

Section IV gives basic maintenance information.

HOW TO ORDER

To order an Operating or Service Manual for your Electronic Counter, contact your nearest Hewlett-Packard Sales and Service Office. Lists are provided at the back of this manual. Give complete 8-digit serial number and name of instrument. Comments and suggestions concerning this manual are welcome at any Sales and Service Office.

TABLE OF CONTENTS

Section		Page
I	GENERAL INFORMATION	1-1
1-1.	Introduction	1-1
1-2.	Description	1-1
1-6.	Identification	1-1
1-8.	Available Plug-In Units	1-1
1-9.	Model 5251A Frequency Converter	1-1
1-11.	Model 5252A Prescaler	1-1
1-13.	Model 5253B Frequency Converter	1-1
1-15.	Model 5254A Frequency Converter	1-1
1-17.	Model 5254B Frequency Converter	1-1
1-19.	Model 5255A Frequency Converter	1-1
1-21.	Model 5258A Sensitive Prescaler	1-3
1-23.	Model 5261A Video Amplifier	1-3
1-25.	Model 5262A Time Interval Unit	1-3
1-27.	Model 5264A Preset Unit	1-3
1-30.	Model 5265A Digital Voltmeter	1-3
1-32.	Applications	1-3
1-33.	General	1-3
1-35.	Terminology	1-3
1-37.	Options	1-4
II	INSTALLATION	2-1
2-1.	Introduction	2-1
2-3.	Unpacking and Inspection	2-1
2-5.	Storage and Shipment	2-1
2-8.	Rack Installation	2-1
2-10.	Power Connection	2-2
2-13.	Cooling	2-2
2-15.	Plug-In Installation	2-2
III	OPERATION	3-1
3-1.	Introduction	3-1
3-3.	Interpreting Display	3-1
3-5.	Accuracy	3-1
3-7.	Digital Recorder Output Option 03, 04, or 05	3-1
3-9.	5251A Frequency Converter	3-9
3-11.	Front Panel	3-9
3-16.	Maximum Input Voltages	3-9
3-18.	Operating Procedure	3-9
3-21.	Typical Frequency Measurements	3-9
3-23.	5252A Prescaler	3-11
3-25.	Controls and Input	3-11
3-30.	Operating Procedure	3-11
3-32.	5253B Frequency Converter	3-11
3-34.	Front Panel	3-11
3-39.	Maximum Input Voltages	3-13
3-41.	Operating Procedures	3-13
3-46.	Double-Checking Frequency Measurement Result	3-13
3-48.	5254B Frequency Converter	3-14
3-51.	Controls and Input	3-14
3-56.	Maximum Input Voltages	3-14
3-58.	Frequency Measurement With Amplitude Less Than 50 MV RMS	3-14
3-60.	Double-Checking Frequency Measurement Result	3-16
3-62.	5255A Frequency Converter	3-16
3-65.	Controls and Inputs	3-17
3-72.	Maximum Input Voltages	3-17
3-74.	Frequency Measurement With Amplitude Less Than 50 MV RMS	3-17
3-76.	Double-Checking Frequency Measurement Result	3-17

TABLE OF CONTENTS

Section		Page
III	OPERATION (Cont'd)	
3-78.	5258A Sensitive Prescaler	3-22
3-82.	Front Panel	3-22
3-88.	Maximum Input Voltages	3-22
3-90.	Operating Procedure	3-22
3-92.	5261A Video Amplifier	3-22
3-94.	Front Panel	3-22
3-100.	Operating Procedure	3-24
3-102.	Operation With Pulse-Input Signals	3-24
3-104.	Operation With High Impedance Probe	3-24
3-106.	Video Amplifier Input Impedance	3-24
3-108.	5262A Time Interval Unit	3-25
3-111.	Controls	3-25
3-115.	Eliminating DC Component From Sine Wave Input	3-25
3-119.	Phase Measurement	3-28
3-123.	5264A Preset Unit	3-28
3-125.	Front Panel	3-28
3-127.	Accuracy	3-28
3-129.	Operating Procedure	3-28
3-131.	Output Voltage	3-28
3-133.	5265A Digital Voltmeter	3-33
3-136.	Front Panel	3-33
3-143.	Digital Voltmeter Calibration	3-33
3-145.	Operating Procedure	3-33
IV	MAINTENANCE	
4-1.	Introduction	4-1
4-3.	Air Filter	4-1
4-5.	Fuse Replacement	4-1
4-7.	Oscillator Calibration	4-1

LIST OF TABLES

Table		Page
1-1.	Specifications	1-2
1-2.	Four-Line Code Truth Table	1-4
1-3.	5246L Options	1-4
1-4.	1248 Code Truth Table	1-4
1-5.	Plug-In Specifications	1-5
2-1.	115/230 Volt Conversion	2-2
3-1.	Decimal Point BCD Out	3-1
3-2.	Measurement Units BCD Out	3-1
3-3.	Summary of Connections to Digital Recorder Jack	3-2
3-4.	Frequency Resolution	3-9
3-5.	Special Counter Display	3-9
3-6.	Frequency Measurement	3-13
3-7.	Frequency Resolution	3-14
3-8.	Typical Double-Check Frequency Measurement	3-16
3-9.	Typical Double-Check Frequency Measurement	3-17
3-10.	Model 5255A Typical Frequency Measurements	3-19
3-11.	Frequency Resolution	3-24
4-1.	Fuse Replacement	4-1
4-2.	Assembly Designations	4-1
4-3.	Self Check	4-2

LIST OF ILLUSTRATIONS

Figure		Page
1-1.	Model 5246L and Accessories	1-0
1-2.	Binary Symbol	1-3
2-1.	Conversion for Rack Mounting	2-1
3-1.	Measurement Accuracy	3-1
3-2.	Operating Controls (Front Panel)	3-3
3-3.	Operating Controls (Rear Panel)	3-4
3-4.	Self Check	3-5
3-5.	Frequency Measurements	3-6
3-6.	Frequency Ratio Measurements	3-7
3-7.	Model 5251A Operating Procedure	3-8
3-8.	Model 5251A Block Diagram	3-10
3-9.	Model 5252A Operating Procedure	3-10
3-10.	Model 5252A Block Diagram	3-11
3-11.	Model 5253B Operating Procedure	3-12
3-12.	Model 5253B Block Diagram	3-13
3-13.	Model 5254B Operating Procedure	3-15
3-14.	Model 5254B Block Diagram	3-16
3-15.	Model 5255A Operating Procedure	3-18
3-16.	Model 5255A Block Diagram	3-20
3-17.	Model 5258A Operating Procedure	3-21
3-18.	Model 5258A Block Diagram	3-22
3-19.	Model 5261A Operating Procedure	3-23
3-20.	Model 5261A Block Diagram	3-24
3-21.	Model 5261A Input Impedance	3-24
3-22.	Model 5262A Trigger Level Settings	3-25
3-23.	Remove DC from Sine Wave Input	3-25
3-24.	Model 5262A Operating Procedure	3-26
3-25.	Model 5262A Operating Procedure Phase Measurements	3-27
3-26.	Model 5262A Block Diagram	3-28
3-27.	Model 5264A Operating Procedure N x FREQ	3-29
3-28.	Model 5264A Operating Procedure PRESET	3-30
3-29.	Model 5264A Operating Procedure f/N	3-31
3-30.	Model 5264A Block Diagram	3-32
3-31.	Model 5265A Block Diagram	3-33
3-32.	Model 5265A Operating Procedure	3-34
4-1.	Test Setups for Checking Oscillator Frequency	4-2

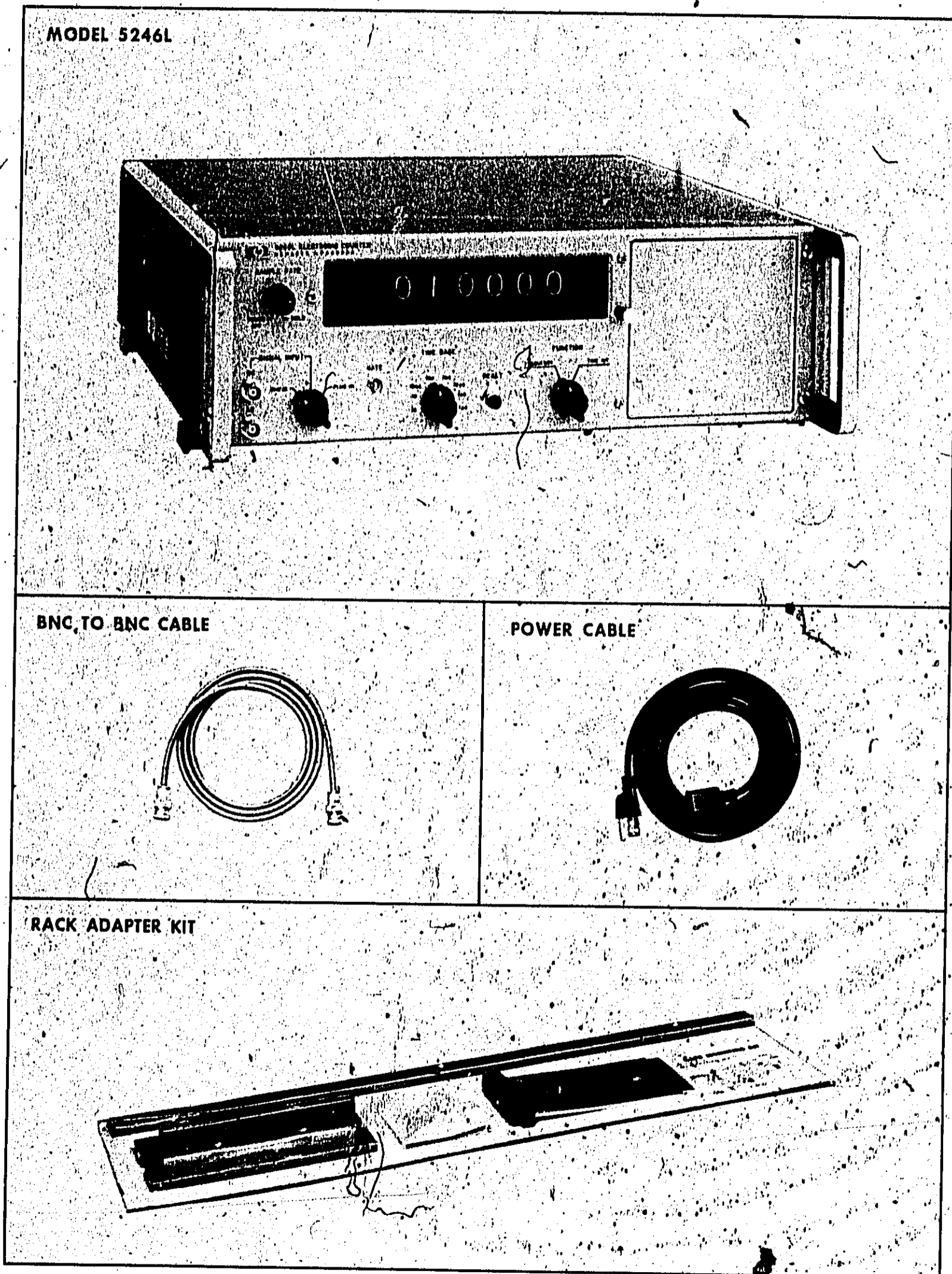

Figure 1-1 Model 5246L and Accessories

SECTION I GENERAL INFORMATION

1-1. INTRODUCTION.

1-2. DESCRIPTION.

1-3. The *hp* Model 5246L Electronic Counter is a high-frequency, general-purpose electronic counter. The Model 5246L measures frequencies from 0 to 50 MHz.

1-4. The *hp* Model 5246L provides these additional features:

a. Display storage which permits reading to be displayed while new count is made.

b. Six-digit display using rectangular (narrow) digital display tubes; decimal point position and measurement units displayed automatically.

c. Operation with plug-in units which extend the basic range and performance of the counter.

1-5. The Model 5246L features solid state design, low power consumption, small size (5-1/4 inch panel height), light weight (28 lbs), easy conversion for rack mounting, and modular plug-in circuit boards for simplified maintenance.

1-6. IDENTIFICATION.

1-7. Hewlett-Packard uses a two-section, eight-digit serial number (on instrument rear panel) to identify instruments (000-00000). The first three digits are a serial prefix number, and the last five digits refer to a specific instrument. If the serial prefix on your instrument does not appear on the title page of this manual, there are differences between the manual and your instrument which are described in a change sheet included with the manual. If the change sheet is missing, the information can be supplied by your nearest Hewlett-Packard Sales and Service Office.

1-8. AVAILABLE PLUG-IN UNITS.

1-9. MODEL 5251A FREQUENCY CONVERTER.

1-10. The *hp* Model 5251A Frequency Converter extends the frequency range of the Model 5246L to 100 MHz. The Model 5251A mixes a selected 10 MHz harmonic (between 20 and 90 MHz) with the input signal. The resulting difference-frequency signal is amplified and provided to the basic counter for counting and display. Because the selected 10 MHz harmonic is derived from a harmonic generator driven by a 10 MHz output from the basic counter, the stability and accuracy of the basic counter are retained.

1-11. MODEL 5252A PRESCALER.

1-12. The *hp* Model 5252A Prescaler Unit is a plug-in unit which converts the *hp* Model 5246L Electronic

Counter into a direct reading counter from DC to 350 MHz. Prescaling is accomplished, without tuning, by transistor binary dividers, operating over the frequency range DC to 350 MHz. Multiple scaling factors (2, 4, or 8) are provided to shorten scaling time at the lower frequencies.

1-13. MODEL 5253B FREQUENCY CONVERTER.

1-14. The *hp* Model 5253B Frequency Converter extends the frequency range of the Model 5246L to 512 MHz. The stability and basic accuracy are retained by multiplying a 10 MHz signal, derived from the counter's internal time base, to a known harmonic frequency. When this harmonic frequency is selected and mixed with the input signal frequency, the difference frequency produced is within the range of the basic counter and is displayed by the counter.

1-15. MODEL 5254A FREQUENCY CONVERTER.

1-16. The *hp* Model 5254A Frequency Converter provides the Model 5246L with a frequency range from 300 to 3000 MHz. The stability and accuracy of the basic counter are retained by using a 50 MHz multiple of the crystal oscillator signal from the counter to beat with the signal being measured. The difference frequency produced is within the range of the basic counter and is displayed by the counter. The converter has an indicator which aids in frequency selection and indicates the output level to the counter. The required input signal level is 50 mV rms to 1 V rms. The input connector is a type N female.

1-17. MODEL 5254B FREQUENCY CONVERTER.

1-18. The *hp* Model 5254B Frequency Converter provides the Model 5246L with a frequency range from 200 to 3000 MHz. The stability and accuracy of the basic counter are retained by using a 50 MHz multiple of the crystal oscillator signal from the counter to beat with the signal being measured. The difference frequency produced is within the range of the basic counter and is displayed by the counter. The converter has an indicator which aids in frequency selection and indicates the output level to the counter. The required input signal level is 50 mV rms to 1 V rms. The input connector is a type N female. The output of the video amplifier (1 to 50 MHz) is available at the AUX OUT jack on the front panel.

1-19. MODEL 5255A FREQUENCY CONVERTER.

1-20. The *hp* Model 5255A Frequency Converter provides the *hp* Model 5246L with a frequency range from 3 to 12.4 GHz. The stability and accuracy of the counter is retained by the use of a heterodyne signal frequency (a selected harmonic from a 200 MHz comb spectrum) which is derived from the 5246L time base. The 5246L displays the converter's difference fre-

Table 1-1 Specifications

FREQUENCY MEASUREMENTS

Range: 0 to 50 MHz (dc coupled input). 25 Hz to 50 MHz (ac coupled input, maximum sensitivity).

Gate Time: 1 μ sec to 1.0 seconds in decade steps.

Accuracy: ± 1 count \pm time base accuracy.

Reads In: kHz or MHz with positioned decimal point; units annunciator in line with digital display.

Self Check: Counts 10 MHz for the gate time chosen by the time base selector switch.

TIME BASE

Frequency (Internal): 1 MHz.

Stability: Aging rate: less than ± 2 parts in 10^7 per month.

As a function of line voltage: less than ± 1 part in 10^7 for changes of $\pm 10\%$.

As a function of ambient temperature: less than ± 2 parts in 10^6 ($+10^\circ$ to $+50^\circ\text{C}$), ± 20 parts in 10^6 (0° to $+65^\circ\text{C}$).

External Input: Sensitivity: 1 volt rms into 500 ohms, sine wave. Range: 100 Hz to 1 MHz, sine wave.

Output Frequency: 1 MHz, 3 V peak-to-peak into 1000 ohms.

GENERAL

Registration: 6 digits in-line with rectangular Nixie tubes and display storage; 999,999 / maximum display.

Display Storage: Holds reading between samples; switch overrides storage.

Sample Rate: Time following a gate closing during which the gate may not be reopened is continuously variable from less than 0.2 sec to 5 seconds in frequency mode, independent of gate time; display can be held indefinitely.

GENERAL (Cont'd)

Operating Temperature Range: 0°C to $+65^\circ\text{C}$.

Connectors: BNC type.

SIGNAL INPUT

Maximum Sensitivity: 100 mV rms; coupling, AC or DC. AC coupling has 0.022 μ F 600 V DC capacitor (-3 dB at approximately 7 Hz).

Impedance: 1 meg shunted by 25 pF.

Overload: Diode clamps in series with 100 K and 0.001 μ F protect input circuit for up to 120 V rms. Input resistance for overload condition (beyond approx. 1 V) is approximately 0.1 megohm.

Weight: Net, 28 lbs (12.8 kg) with blank plug-in; shipping, 36 lbs (16.4 kg).

Dimensions:

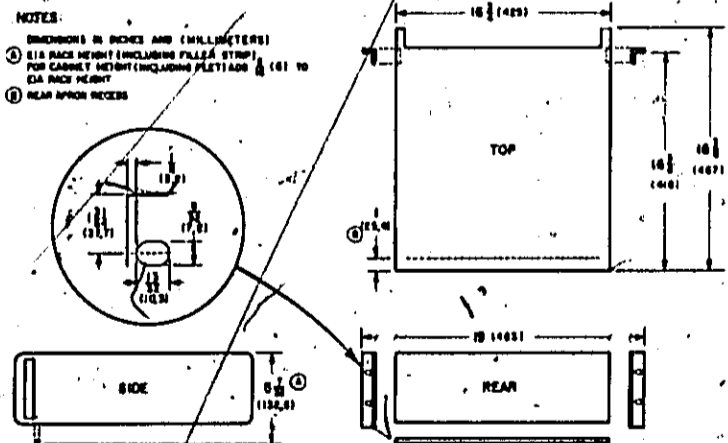

Power Supply: 115 or 230 volts $\pm 10\%$, 50 to 60 Hz; 95 watts (50 to 1000 Hz operation, price on request).

Accessories Furnished: HP 10503A Cable, 4 feet long, male BNC connectors. Detachable Power Cord, 7-1/2 feet (2040 mm) long, NEMA plug. Circuit Board Extender.

Options: See Table 1-3.

Model 5246L

quency to the nearest cycle with the counter TIME BASE switch set to 1 sec. Adding this reading to the 5255A dial reading (3 to 12.4 GHz) gives the input frequency value with a resolution of up to 1 Hz.

1-21. MODEL 5258A SENSITIVE PRESCALER.

1-22. The Model 5258A Sensitive Prescaler Unit extends the direct counting range of the Model 5246L to 200 MHz. It extends the input sensitivity in the 1 MHz to 200 MHz range to 1 mV rms and can be used as a video amplifier. Input frequency prescaling (dividing) is done without tuning by transistor binary dividers operating from 1 MHz to 200 MHz. At the same time, the prescaler adjusts the counter's time base an equal amount to provide direct readout in frequency.

1-23. MODEL 5261A VIDEO AMPLIFIER.

1-24. The Model 5261A Video Amplifier Unit extends the sensitivity of the Model 5246L to 1.0 millivolt over the frequency range of 10 Hz to 50 MHz. Input impedance is 1 megohm and can be further increased by 10 megohms by use of an accessory 10:1 divider probe (Model 10003A) for signals greater than 10 mV. A 50 ohm output is provided for oscilloscope monitoring of the amplified signal.

1-25. MODEL 5262A TIME INTERVAL UNIT.

1-26. The Model 5262A Time Interval Unit provides start and stop pulses, initiated by electrical inputs, to the main count gate in the Model 5246L, enabling it to make time interval measurements. Time intervals from 1 microsecond to 10^8 seconds are measured with a resolution of 0.1 microsecond. Basic counter accuracy is retained when the signal counted is derived from the internal oscillator.

1-27. MODEL 5264A PRESET UNIT.

1-28. The Model 5264A Preset Unit converts the 5246L to a preset time base counter while retaining its basic measurement functions and range. The Model 5264A permits the 5246L to:

- measure normalized frequency rate ($N \times \text{FREQ}$)
- count N events (PRESET)
- divide an input frequency by N (f/N)

In these measurements N may be any integer from 1 to 100,000 ($N = 100,000$ when all N switches are set to 0).

1-29. Such versatility is achieved by using a set of decade dividers in the 5264A to control the gate of the counter. These decade dividers, which may be preset to any integer from 1 to 100,000, open the counter's gate when the first pulse is received and close the gate when the N th pulse is received.

1-30. MODEL 5265A DIGITAL VOLTMETER.

1-31. The Model 5265A Digital Voltmeter converts the 5246L to an accurate DC digital voltmeter. DC

voltages as high as 1000 volts can be measured with six-digit presentation. Accuracy of the Digital Voltmeter is $\pm 0.1\%$ of the displayed reading or 0.01% of the full-range value for operating temperatures between $+15^\circ\text{C}$ and $+40^\circ\text{C}$. Accuracy is maintained for over-range voltages of 5% on all ranges. The LOCAL-REMOTE switch permits remote selection of the digital voltmeter mode of operation from the plug-in controls. Polarity of the input DC voltage is automatically sensed and displayed.

1-32. APPLICATIONS.

1-33. GENERAL.

1-34. The Model 5246L can measure frequencies from 0 to 50 MHz directly, to 12.4 GHz when used with available plug-in units, and to 18,000 MHz when used with the Model 540B Transfer Oscillator and Model P932A Harmonic Mixer. It can measure speed, rpm, acceleration, vibration, and other phenomena when they are converted to sine waves or pulses. It can simplify the design, test, and calibration of filters, oscillators, scalars, and other devices which require critical frequency or time interval measurements in their manufacture or maintenance.

1-35. TERMINOLOGY.

1-36. The definitions of the following terms apply to those terms as they will be used throughout the manual.

a. **BINARY.** A bistable multivibrator (flip-flop) used to count or store binary information. The output of each binary is a "bit" or binary digit.

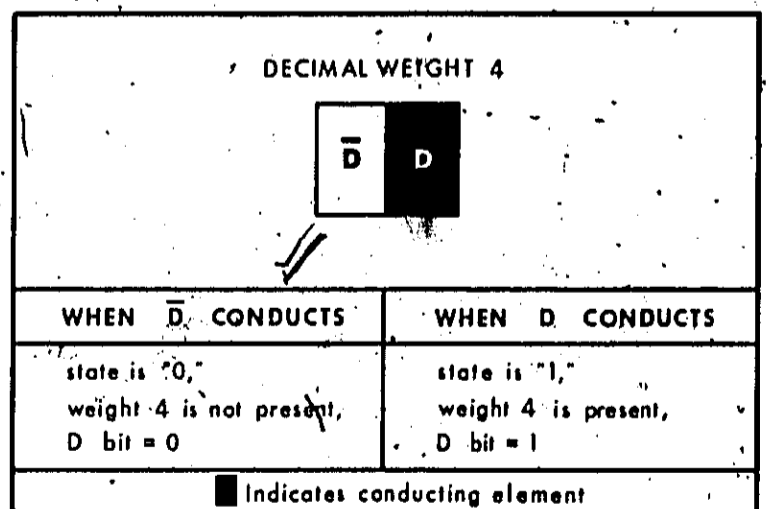

Figure 1-2. Binary Symbol.

b. **DECIMAL WEIGHT.** Numerical value assigned to the output of each binary. In a 1224 code, decimal weights are assigned as follows: A binary, 1; B binary, 2; C binary, 2; D binary, 4.

c. **"1" STATE.** One transistor in binary conducting, output of binary indicates decimal weight present.

d. **"0" STATE.** Opposite transistor in binary conducting, output of binary indicates decimal weight absent.

Section I

Model 5246L

e. 4-LINE BCD. Four-line binary-coded-decimal; decimal information coded in such a way that each decimal digit may be represented by a unique combination of 1 and 0 states of four binaries.

f. TRUTH TABLE. A table which lists the allowable 1 or 0 states of a system of binaries for each decimal digit to be represented. These states are listed in an order which presents the most significant digit first. Example: In a 1224 code, binaries D, C, B, and A are assigned decimal weights of 4, 2, 2, and 1 respectively. The decimal numeral 5 is represented by state 0111 and weights of 2, 2, and 1 are present. The allowable combination (0111) is listed in the truth table (Table 1-2).

Table 1-2. Four-Line Code Truth Table

Digit	4-Line Code, 1224, 0-, 1+			
	D = 4	C = 2	B = 2	A = 1
0	0	0	0	0
1	0	0	0	1
2	0	0	1	0
3	0	0	1	1
4	0	1	1	0
5	0	1	1	1
6	1	1	0	0
7	1	1	0	1
8	1	1	1	0
9	1	1	1	1

1-37. OPTIONS.

1-38. Table 1-3 lists the available options for the 5246L. Complete details are given in Section V of the 5246L Service Manual.

1-39. Table 1-4 is a truth table for the 1248 BCD code.

1-40. Decimal point and measurement units assemblies that provide a 1248 BCD output code are available by special order. They are not included as part of Option 04 and 05.

Table 1-3. 5246L Options

01: 7 digit readout
02: 8 digit readout
03: 1224 "1" state positive 4 line BCD output "0" State Level: -8 V "1" State Level: +18 V Impedance: 100K ohms, each line BCD Reference Levels: Approximately +17 V, 350Ω source Approximately -6.5 V, 1000Ω source Output is suitable for systems use or output devices such as Models 580A and 581A Digital to Analog Converters. Print Command: +13 V to 0 V step, DC coupled. Hold-off Requirement: +15 V min, +25 V max. from chassis ground (1000Ω source). Cable Connector: Amphenol 50 pin 57-30500, 1 required.
04: Similar to Option 03 except output is 1248 "1" state negative 4 line BCD.
05: Similar to Option 03 except output is 1248 "1" state positive 4 line BCD.
06: High Stability Time Base Oscillator: Aging Rate: less than 3 parts in 10 ⁹ per 24 hours after 72 hours warm-up. As a function of temperature: less than ±2 parts in 10 ¹⁰ per °C from -20°C to +55°C. As a function of line voltage: less than ±5 parts in 10 ¹⁰ for ±10% change in line voltage from 115 V or 230 V rms. Short term: less than 2 parts in 10 ¹⁰ rms with measurement averaging time of one second under constant environmental and line voltage conditions.

Table 1-4. 1248 Code Truth Table

Digit	Option 04 0 = +18V, 1 = -8V Option 05 0 = -8V, 1 = +18V			
	D = 8	C = 4	B = 2	A = 1
0	0	0	0	0
1	0	0	0	1
2	0	0	1	0
3	0	0	1	1
4	0	1	0	0
5	0	1	0	1
6	0	1	1	0
7	0	1	1	1
8	1	0	0	0
9	1	0	0	1

Table 1-5. Plug-In Specifications

5251A 20 to 100 MHz Frequency Converter* †	5253B 50 to 512 MHz Frequency Converter* †
<p>Range: 20 MHz to 100 MHz, using mixing frequencies of 20 MHz to 90 MHz in 10 MHz steps.</p> <p>Accuracy: Retains accuracy of basic counter.</p> <p>Input Voltage Range: 50 mV to 1 V rms.</p> <p>Maximum Input: 2 V rms or ± 100 Vdc will not damage the instrument.</p> <p>Input Impedance: Approximately 50 ohms.</p> <p>Level Indicator: Meter aids mixing frequency selection; indicates output voltage level to counter.</p> <p>Registration: Counter Display is added to the converter dial reading.</p> <p>Weight: Net 3 lbs (1, 5 kg); shipping 7 lbs (3 kg).</p>	<p>Range: 50 MHz to 512 MHz, using mixing frequencies of 50 MHz to 500 MHz in 10 MHz steps.</p> <p>Accuracy: Retains accuracy of basic counter.</p> <p>Input Voltage Range: 50 mV rms (-13 dBm in 50 ohms) to 1V rms (+13 dBm in 50 ohms).</p> <p>Maximum Input: 2V rms or 250 Vdc will not damage instrument.</p> <p>Input Impedance: Approximately 50 ohms.</p> <p>Level Indicator: Meter aids frequency selection; indicates output voltage level to counter.</p> <p>Registration: Counter display is added to the converter dial reading.</p> <p>Weight: Net 5 lbs (2, 3 kg); shipping 9 lbs (4, 1 kg).</p>
5252A Prescaler* †	5254A/5254B Frequency Converter* †
<p>Operating Frequency Range: Dc to 350 MHz.</p> <p>Accuracy: Same as the basic counter.</p> <p>Input Sensitivity: 100 mV rms.</p> <p>Maximum Input: 2 volts rms, ± 20 dBm, or 100 mW.</p> <p>Input Impedance: 50 ohm (nominal).</p> <p>Operating Temperature Range: 0°C to +55°C.</p> <p>Scaled Output: 100 mV rms into 50Ω is available at the AUX A output BNC connector of the basic counter.</p> <p>Double Pulse Resolution: 2.8 ns</p> <p>Minimum Pulse Amplitude: 280 mV.</p> <p>Weight: Net 2.2 lbs (1 kg); shipping 6-3/4 lbs (3, 1 kg).</p>	<p>Range: 5254A: 300 to 3000 MHz. 5254B: 200 to 3000 MHz.</p> <p>Accuracy: Same as the basic counter.</p> <p>Input Signal Level: 50 mV rms (-13 dBm in 50 ohms) to 1V rms (+13 dBm in 50 ohms).</p> <p>Input Overload: Input power in excess of 100 mW (+2 dBm or 2.2V rms) may damage the converter.</p> <p>Input Impedance: Approximately 50 ohms.</p> <p>Input Connector: Type N female.</p> <p>Level Indicator: Meter aids frequency selection; indicates output voltage level to counter.</p> <p>Registration: Counter display in MHz is added to the converter dial reading.</p> <p>Weight: Net, 5 lbs (2, 5 kg); shipping 9 lbs (4 kg)</p>
<p>*When installed in the Model 5246L Electronic Counter.</p>	
<p>† A 50-ohm coaxial cable, 48 inches long (HP Part No. 10503A) male BNC to male BNC, is furnished with all of the above instruments.</p>	

Table 1-5. Plug-In Specifications Cont'd.

<p style="text-align: center;">5255A</p> <p style="text-align: center;">3 to 12.4 GHz Frequency Converter*</p>	<p style="text-align: center;">5258A</p> <p style="text-align: center;">1 to 200 MHz Sensitive Prescaler*†</p>
<p>Range: 3 to 12.4 GHz using mixing frequencies of 2.8 12.4 GHz in 200 MHz steps. As a prescaler, 1 MHz to 200 MHz.</p> <p>Accuracy: Retains accuracy of basic counter.</p> <p>Input Sensitivity: 100 mV rms (-7 dBm) as a converter. 5 mV rms as a prescaler.</p> <p>Input Impedance: 50 ohms nominal (vswr 2 up to 12.4 GHz).</p> <p>Maximum Input: +10 dBm.</p> <p>Level Indicator: Meter aids frequency selection; indicates usable signal level.</p> <p>Auxiliary Output: 1 MHz to 200 MHz difference signal from video amplifier.</p> <p>Registration: Counter display in MHz is added to converter dial reading.</p> <p>Installation: Plugs into front panel plug-in compartment of HP 5246L Electronic Counter.</p> <p>Input Connector: Precision Type N female. GPC-7 connector optional.</p> <p>Weight: Net 8.25 lbs (3, 8 kg) Shipping 13 lbs (5, 5 kg).</p> <p>*When used with the HP 5246L.</p>	<p>Range: 1 MHz to 200 MHz</p> <p>Accuracy: Same as basic counter.</p> <p>Input Sensitivity: 1 mV/10 mV/.2V rms as selected by front panel switch.</p> <p>Resolution: 1 Hz in 4 sec, 10 Hz in 0.4 sec, etc.</p> <p>Input Impedance: 50 ohms</p> <p>Input Scaling Factor: ÷ 4</p> <p>Operating Temperature Range: -20°C to +65°C</p> <p>As a Video Amplifier: 30 dB maximum gain on 1 mV range.</p> <p>Weight: Net 4.75 lb (2, 16 kg) Shipping 9.25 lb (4, 2 kg)</p> <p>*When installed in the HP Model 5246L Elec- tronic Counter.</p> <p>†A 50-ohm, coaxial cable, 48 inches long (HP Part No. 10503A) male BNC to male BNC is supplied with the 5258A.</p>

Table 1-5. Plug-In Specifications Cont'd.

5261A VIDEO AMPLIFIER†*	
<p>Bandwidth: 10 Hz to 50 MHz with 5246L.</p> <p>Input Sensitivity: 1 mV to 300 mV rms.</p> <p>Input Impedance: Approximately 1 megohm, 15 pf shunt; HP 10003A Probe increases impedance to 10 megohms, 10 pf shunt.</p> <p>Attenuator Ranges: 1, 3, 10, 30 and 100 mV rms.</p> <p>Maximum Input: 100 volts dc, 5 volts rms (ranges: 1, 3, 10, 30, 100 mV).</p> <p>Monitor: Meter shows when the signal level is acceptable to the counter.</p>	<p>Accuracy: Retains accuracy of basic counter.</p> <p>50-Ohm Output: Separate BNC front panel output for oscilloscope monitoring or for driving external equipment; 50-ohm source impedance. On amplifier's most sensitive attenuator range, 1 mV rms at input results in at least 100 mV rms at auxiliary output into 50-ohm load. Maximum undistorted output is 300 mV rms into 50-ohm load.</p> <p>Weight: Net 2 lb (0, 90 kg); shipping 8 lbs (3, 8 kg).</p> <p>†A 50Ω, low microphonic cable (10507A) male BNC to male BNC is supplied with the 5261A.</p>
5262A TIME INTERVAL UNIT*	
<p>Range: 1 μsec to 10⁸ sec (start and stop pulses must be separated by 1 μsec to give useful readings).</p> <p>Accuracy: ± 1 period of standard frequency counted ± time base accuracy.</p> <p>Registration: On Model 5246L Electronic Counter.</p> <p>Input Voltage: 0.3 volt, peak-to-peak, minimum, direct coupled input.</p> <p>Input Impedance: 10K ohms, less than 80 pf, on X. 1 and X. 2 multiplier positions; constant up to ± 40 volts peak times multiplier position. 100K ohms times multiplier position on X. 3 to X100 positions, less than 40 pf on X. 3, and less than 20 pf on X1 to X100; constant up to ± 40 volts times multiplier position.</p> <p>Overload: 50 volts rms, or ± 150 volts peak on X. 1, .2, and .3 multiplier positions is tolerable; 150 volts rms, or ± 250 volts peak, on X1 and X3; 250 volts rms or ± 250 volts peak, on X10, 30, and 100.</p> <p>Start Stop: Independent or common channels.</p>	<p>Trigger Slope: Positive or negative on Start and Stop channels, independently selected.</p> <p>Trigger Amplitude: Both channels continuously adjustable from -250 volts to +250 volts.</p> <p>Frequency Range: (When used as an input signal discriminator): 0 to 2 MHz.</p> <p>Standard Frequency Counted: 10⁷ to 1 Hz in decades from 5246L, or externally applied frequency.</p> <p>Markers: Separate output voltage steps, 0.5 volts peak-to-peak from source impedance of approximately 7K ohms, 100 pf; available at rear panel of the 5246L with negative step coincident with trigger points on input waveforms for positive slope and positive step coincident for negative slope.</p> <p>Reads In: μs, ms, sec with measurement units indicated and decimal point positioned.</p> <p>Accessory Supplied: 50-ohm coaxial cable, 48" long (HP Part No. 10503A) male BNC to male BNC.</p> <p>Weight: Net 2 lb (0, 90 kg); shipping 7 lbs (3, 2 kg)</p>
*When installed in the HP, Model 5246L Electronic Counter	

Table 1-5. Plug-In Specifications Cont'd.

5264A PRESET UNIT*†	
<p><u>N x FREQ (Counter Input):</u> Range: 5246L: .0 to 50 MHz</p> <p>Gate Time: (set by Counter Time Base and "N" switches): 10 μsec to 1 sec in 10-μsec steps 100 μsec to 10 sec in 100-μsec steps 1 msec to 100 sec in 1-msec steps 10 msec to 10³ sec in 10-msec steps 0.1 sec to 10⁴ sec in 0.1-sec steps 1 sec to 10⁵ sec in 1-sec steps</p> <p>Accuracy: ± 1 count \pm time base accuracy</p> <p>Maximum Counter Sensitivity: 0.1 volt rms</p> <p>Counter Input Impedance: 1 megohm, 25 pf shunt</p> <p><u>PRESET (AUX INPUT on Preset Unit):</u> Input Frequency Range: 20 Hz to 100 kHz</p> <p>Maximum Sensitivity: 0.1 volt rms</p> <p>Input Impedance: 1MΩ; 50 pf shunt</p> <p>Preset Range: 1 to 99,999 in steps of one</p>	<p><u>DIVIDE BY N (AUX Input on Preset Unit):</u> Frequency Range: 20 Hz to 100 kHz, sinusoidal</p> <p>Presetting: N decade steps to 10⁹ to maximum rate of Counter (scaled output frequency 100 kHz).</p> <p>Output: Pulses, .2 volt peak-to-peak centered at 0 volts into a high impedance load, less than 1 μsec rise time, approximately 5 μsec duration</p> <p>Sensitivity: 0.1 volt rms</p> <p>Input Impedance: 1 M ohm, 50 pf shunt</p> <p>Weight: Net 3 lbs, 2 oz. (1, 4 kg); Shipping 9 lbs (4 kg)</p> <p>*When installed in HP 5246L Counter. †A 50-ohm coaxial cable, 48" long (HP Part No. 10503A) male BNC to male BNC, is furnished with the 5264A.</p>

Table 1-5. Plug-In Specifications Cont'd.

5265A
DIGITAL VOLTMETER*†

Voltage Range:
Six-digit presentation of 10.0000, 100.000, and 1000.00 volts full scale with 5% over-range capability. (Common terminal is INSTRUMENT GROUND.)

Range Selection:
Manual

Input Resistance:
10.2 megohms to DC, on all ranges

Registration:
On Model 5246L.

Input Filter AC Rejection:
30 dB at 60 Hz, increasing at 12 dB per octave.

Reads In:
Dc volts with decimal point positioned by range switch; automatic polarity indicator.

Input Filter Response Time:
Less than 450 msec to a step function to within 99.95% of final value.

Accuracy: (0 to 50°C):
±0.1% of reading, ±0.01% of full scale.

Weight:
Net 2-1/2 lbs (1,1 kg); shipping 7 lbs (3,2 kg).

*When used with 5246L Electronic Counter.

†22-pin extender board is supplied with the Model 5265A.

PLUG-IN DIMENSIONS:

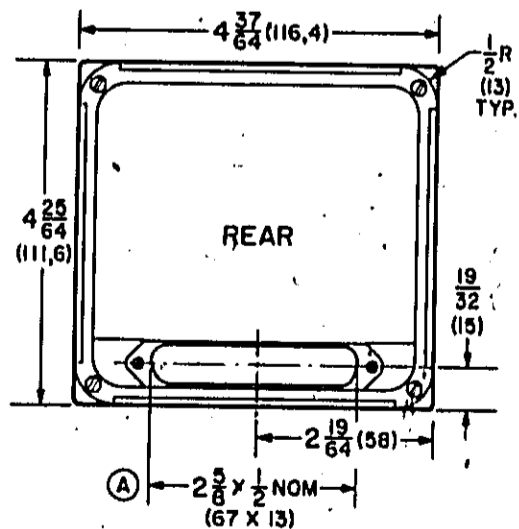
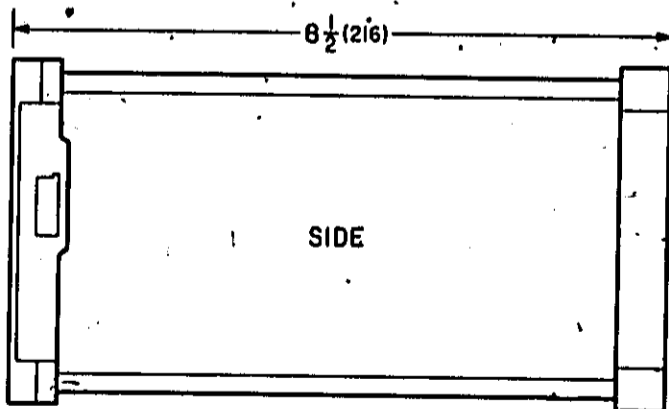

NOTE
DIMENSIONS IN INCHES AND (MILLIMETERS)
(A) CONNECTOR, AMPHENOL NO. 57-10500

SECTION II INSTALLATION

2-1. INTRODUCTION.

2-2. This section contains information on unpacking, inspection, repacking, storage, and installation.

2-3. UNPACKING AND INSPECTION

2-4. If the shipping carton is damaged, ask that the carrier's agent be present when the instrument is unpacked. Inspect the instrument for damage (scratches, dents, broken knobs, etc). If the instrument is damaged or fails to self check (Self Check Procedure, Figure 3-4), notify the carrier and the nearest Hewlett-Packard field office immediately (field offices are listed at the back of this manual). Retain the shipping carton and the padding material for the carrier's inspection. The field office will arrange for the repair or replacement of your instrument without waiting for the claim against the carrier to be settled.

2-5. STORAGE AND SHIPMENT.

2-6. **PACKAGING.** To protect valuable electronic equipment during storage or shipment always use the best packaging methods available. Your Hewlett-Packard field office can provide packing material such as that used for original factory packaging. Contract packaging companies in many cities can provide dependable custom packaging on short notice. Here are a few recommended packaging methods:

a. **RUBBERIZED HAIR.** Cover painted surfaces of instrument with protective wrapping paper. Pack instrument securely in strong corrugated container (350 lb/sq in. bursting test) with 2-inch rubberized hair pads placed along all surfaces of the instrument. Insert fillers between pads and container to ensure a snug fit.

b. **EXCELSIOR.** Cover painted surfaces of instrument with protective wrapping paper. Pack instrument in strong corrugated container (350 lb/sq in. bursting test) with a layer of excelsior about 6 inches thick packed firmly against all surfaces of the instrument.

2-7. **ENVIRONMENT.** Conditions during storage and shipment should normally be limited as follows:

- Maximum altitude, 20,000 feet.
- Minimum temperature -40°F (-40°C).
- Maximum temperature 167°F (75°C).

2-8. RACK INSTALLATION.

2-9. The Model 5246L is ready for bench operation as shipped from the factory. Additional parts necessary for rack mounting are packaged with the instrument. To convert for rack installation, refer to Figure 2-1 and proceed as follows:

- Remove tilt stand.
- Remove feet (press the foot-release button, slide foot toward center of instrument, and lift off).
- Remove adhesive-backed trim strips at front end of sides.
- Attach filler strip along bottom edge of front panel.
- Attach flanges to front end of sides (larger corner-notch toward bottom of instrument). Instrument is now ready to mount in standard rack.

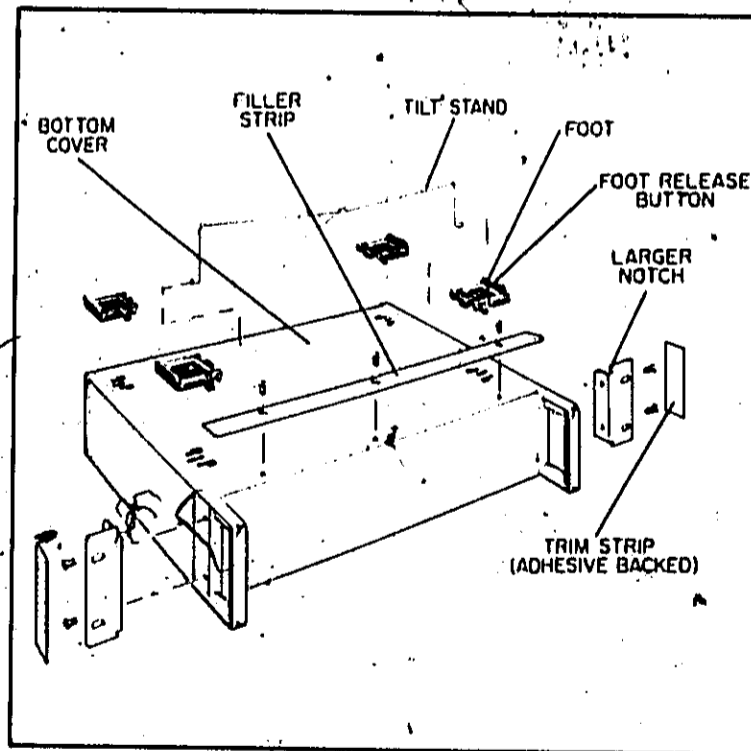

Figure 2-1. Conversion for Rack Mounting

CAUTION

Ambient temperature in rack during operation should not exceed a maximum of 131°F (55°C). Be sure instrument position in rack permits air circulation to intake in center area of rear panel and that nearby instruments do not discharge hot air near intake.

2-10. POWER CONNECTION.

2-11. **LINE VOLTAGE.** The Model 5246L may be operated from either 115- or 230-volt ($\pm 10\%$) power lines. A slide switch on the rear panel permits quick conversion for operation from either voltage. Insert a narrow-blade screwdriver in the switch slot and slide the switch to the right for 230-volt operation ("230" marking exposed) or to the left for 115-volt operation ("115" marking exposed). The Model 5246L is supplied with 115-volt fuse; be sure to replace this fuse for 230-volt operation; see Table 2-1.

CAUTION

Before plugging instrument into AC power line be sure slide switch is properly positioned.

Table 2-1. 115/230 Volt Conversion

Conversion	115 Volt	230 Volt
Slide switch	Left ("115")	Right ("230")
AC LINE FUSE	2 ampere slow-blow (part 2110-0006)	1 ampere slow-blow (part 2110-0007)

2-12. **POWER CABLE.** The Model 5245L is equipped with a detachable 3-wire power cable. Proceed as follows for installation.

a. Connect flat plug (3-socket connector) to AC line jack at rear of instrument.

b. Connect plug (2-blade with round grounding pin) to 3-wire (grounded) power outlet. Exposed portions of instrument are grounded through the round pin on the plug for safety; when only 2-blade outlet is available, use connector adapter (part stock no. 1261-0048), then connect short wire from side of adapter to ground.

2-13. COOLING.

2-14. The Model 5246L uses forced air cooling. The air intake and filter are located on the rear panel of the instrument. Inspect the filter regularly; clean the filter before it becomes dirty enough to restrict air flow (see Paragraph 4-3 for instructions on filter care).

Note

Do not apply coating compounds to non-metal filters.

2-15. PLUG-IN INSTALLATION.

2-16. The plug-in units are installed into the rectangular compartment at the right hand side of the front panel of the Model 5246L. To install the plug-in unit in the counter, turn counter off and remove blank panel from counter by turning the retaining latch knob counterclockwise. Insert plug-in unit into counter and push unit firmly into compartment until front panel of plug-in is flush with the front panel of the counter. Turn the retaining latch knob clockwise until it is tight.

2-17. To remove unit from counter, turn counter off and turn the retaining latch knob counterclockwise to its stop. Then grasp knob or connector and pull unit from counter. If any difficulty is encountered with installation or removal, check that the retaining latch is fully counterclockwise.

SECTION III OPERATION

3-1. INTRODUCTION.

3-2. The counter measures frequency and frequency ratio. The SIGNAL INPUT switch selects the signal source. A TIME BASE switch selects time base or ratio multiplier and a FUNCTION switch selects measurement function. The SAMPLE RATE control adjusts sampling rate. Figures 3-2 and 3-3 describe the front and rear panel operating controls. Figures 3-4 through 3-6 provide step-by-step operating procedures for each measurement function. Measurements made with available plug-in units are described in Paragraphs 3-9 through 3-146. The number or numbers associated with each control indicate the step in which the control is used.

3-3. INTERPRETING DISPLAY.

3-4. Direct readout is provided in the FREQUENCY function with measurement units displayed and with decimal point automatically positioned.

3-5. ACCURACY.

3-6. FREQUENCY MEASUREMENTS. The basic counter accuracy is determined by two factors. One factor is the stability of the 1 MHz crystal standard in the time base, which is 2 parts per ten million or .00002 percent per month. A second factor is the inherent error of ± 1 count present in all counters of this type. This error is due to phasing between the timing pulse that operates the electronic gate and the pulses that pass through the gate to the counters. The chart in Figure 3-1 shows the errors to be expected for the frequency or period measurements.

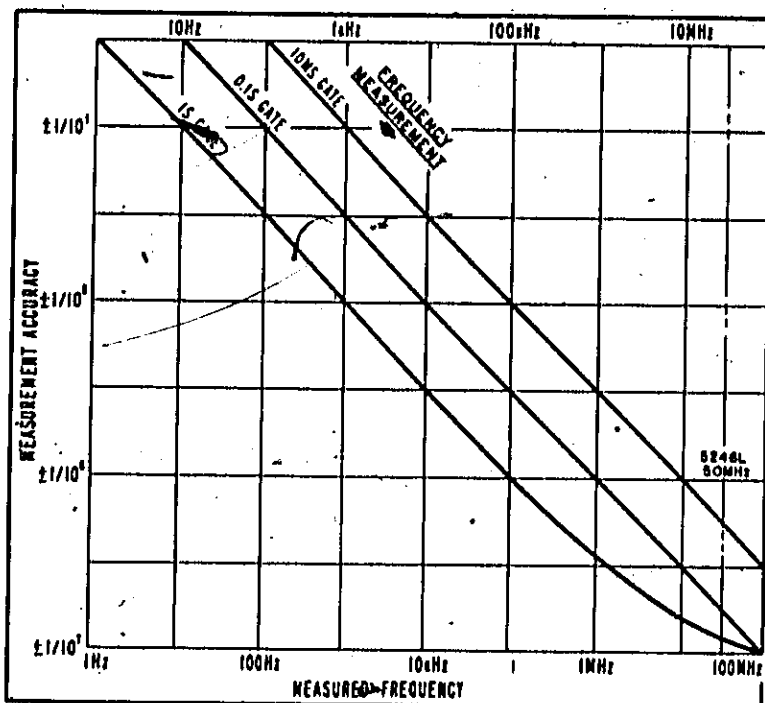

Figure 3-1. Measurement Accuracy

3-7. DIGITAL RECORDER OUTPUT OPTION 03, 04, OR 05.

3-8. To supply counter display information (including all digits, decimal point position, and measurement unit) to the Model 562A Digital Recorder or Model 580A/581A Digital-to-Analog Converter, connect 50-wire cable (Part No. 562A-16C) between rear-panel DIGITAL RECORDER jack on counter and input connector of recorder or converter. Cable can be fabricated for connection to other equipment using an Amphenol 57-30500 connector to mate with the counter DIGITAL RECORDER jack. Tables 3-1 and 3-2 provide output information for decimal point and measurement units recording. Signals available and external signals required are given in Table 3-3.

Table 3-1. Decimal Point BCD Out

DISPLAY	J5 Output (Volts)				Printed Digit
	Pin 45	Pin 44	Pin 20	Pin 19	
0 0 0 0 0 0 0 0	- 8	- 8	- 8	- 8	0
0 0 0 0 0 0 0 0.	- 8	- 8	- 8	- 8	0
0 0 0 0 0 0 0 0.0	- 8	- 8	- 8	+18	1
0 0 0 0 0 0 0 0.00	- 8	- 8	+18	- 8	2
0 0 0 0 0 0 0 0.000	- 8	- 8	+18	+18	3
0 0 0 0.0 0 0 0 0	- 8	+18	+18	- 8	4
0 0 0.0 0 0 0 0 0	- 8	+18	+18	+18	5
0 0.0 0 0 0 0 0 0	+18	+18	- 8	- 8	6
0.0 0 0 0 0 0 0 0	+18	+18	- 8	+18	7

Table 3-2. Measurement Units BCD Out

DISPLAY	J5 Output (Volts)				Printed Digit
	Pin 43	Pin 42	Pin 18	Pin 17	
*	- 8	- 8	- 8	- 8	0
MHz	- 8	- 8	- 8	+18	1
KHz	- 8	- 8	+18	- 8	2
SEC	- 8	- 8	+18	+18	3
MS	- 8	+18	+18	- 8	4
μS	- 8	+18	+18	+18	5

Table 3-3. Summary of Connections to Digital Recorder Jack

Function		J5 Pin No.	Function		J5 Pin No.
Display	Weight		Display	Weight	
(Right End)	1	1	(Left End)	1	15
10^0	2	2	10^7	2	16
Units	2	26	Ten Millions	2	40
	4	27	(Option 02)	4	41
	1	3	Inhibit signal input; +15V min, +25 V max supplied from external source to prevent reset; causes count to hold.	22	
10^1	2	4			
Tens	2	28			
	4	29			
	1	5	Print command output; +13V to 0V step; de-coupled, signals that completed count is available for readout.	48	
10^2	2	6			
Hundreds	2	30			
	4	31			
	1	7	Negative reference output; about -6.5 Vdc.	24	
10^3	2	8			
Thousands	2	32			
	4	33			
	1	9	Positive reference output; about +17Vdc.	25	
10^4	2	10			
Ten Thousands	2	34			
	4	35			
	1	11	Ground	50	
10^5	2	12			
Hundred Thousands	2	36			
	4	37			
	1	13	No connection	21	
10^6	2	14			
Millions	2	38			
(Option 01)	4	39			
				23	
				46	
				47	
				49	

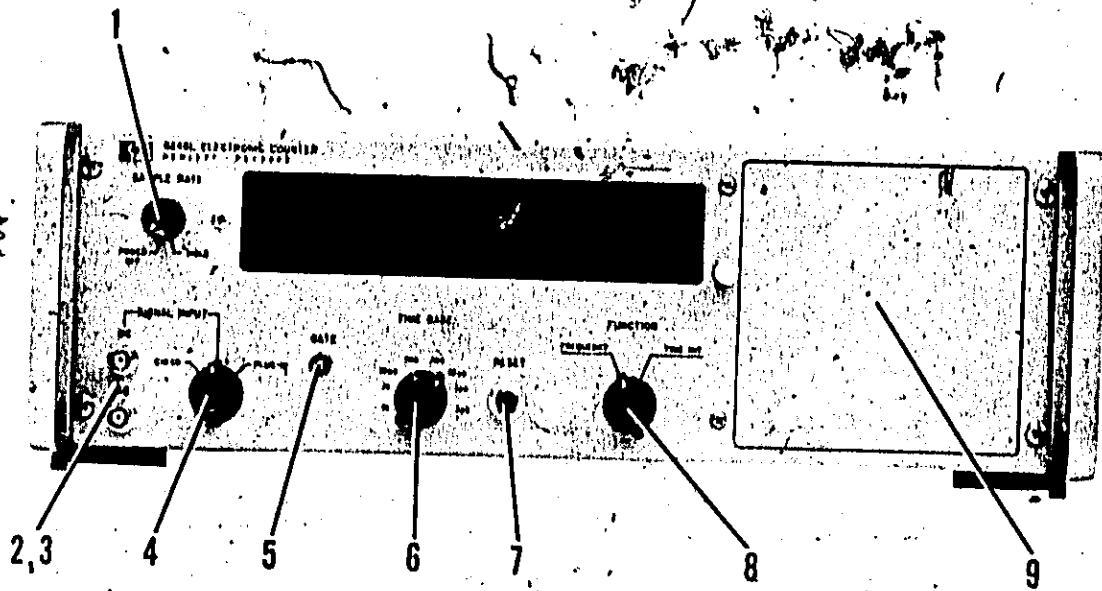

1. SAMPLE RATE

- a. Controls power to all circuits; max. ccw turns POWER OFF.
- b. Controls time between measurements from 0.2 sec to 5 sec.
- c. Causes display to HOLD indefinitely when maximum cw.

2. DC SIGNAL INPUT provides direct coupling to internal amplifier for most measurements.

3. AC SIGNAL INPUT provides coupling to internal amplifier through .022 μ f (600 vdc max).

4. SIGNAL INPUT control selects the source of counted signal: Self Check, External Input, or Plug-in.

5. GATE lamp glows during counting (main gate open).

6. TIME BASE selects time that main gate is on for frequency.

7. RESET pushbutton returns both displayed and internal count to zero when pressed.

8. FUNCTION. Permits measurement of frequency applied to SIGNAL INPUT during interval selected by TIME-BASE switch when in FREQUENCY.

Figure 3-2. Operating Controls (Front Panel)

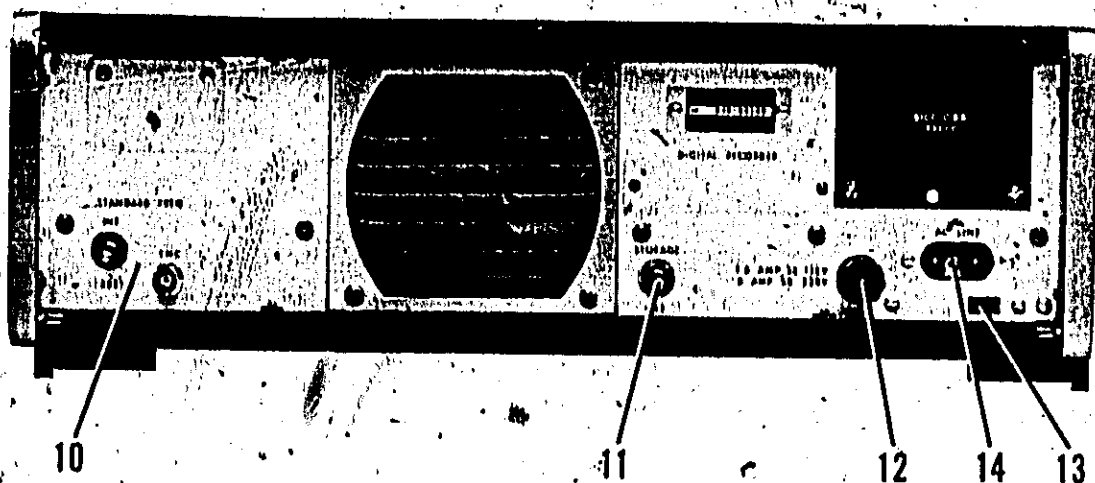

9. Plug-in compartment.
 - a. Receives plug-in unit to extend basic counter capabilities. To install plug-in (1) turn power off, (2) loosen knurled screw at side of compartment, (3) remove blank panel or plug-in unit, (4) slide desired plug-in unit into place and tighten knurled screw.
 - b. Permits access to fine frequency control through panel at rear of compartment.
10. STANDARD FREQ (input or output).
 - a. 1 MHz from internal oscillator continuously available when in INT position.
 - b. Permits use of external 1 MHz frequency standard for time-base control when set to EXT.
11. STORAGE switch provides display storage when up; continuous display of internal count when OFF (down).
12. Fuse provides overload protection; should be 2 ampere slow-blow for 115-volt operation, 1 ampere slow-blow for 230-volt operation.
13. Line-voltage switch permits selection of either 115- or 230-vac line; insert narrow blade and slide to left for 115-volt; slide to right for 230 volt.
14. AC LINE connector connects to flat plug on power cable.

Figure 3-3. Operating Controls (Rear Panel)

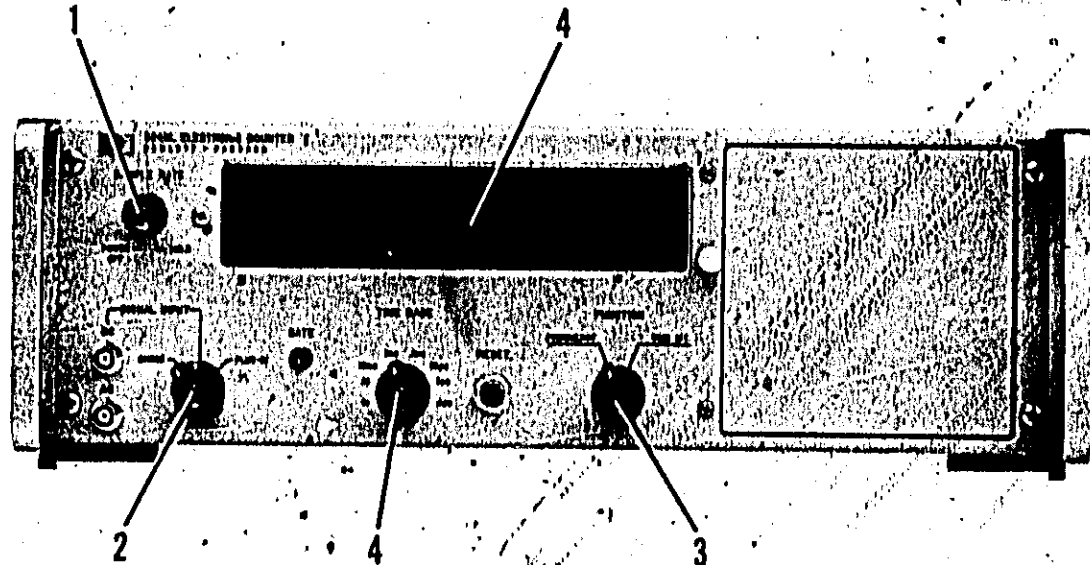

1. Turn SAMPLE RATE control clockwise from POWER OFF position to turn counter on.
2. Set SIGNAL INPUT switch to CHECK.
3. Set FUNCTION switch to FREQUENCY.
4. See table at right for proper display (±1 count for each position of TIME BASE switch).

TIME BASE

1 μs
 10 μs
 .1 ms
 1 ms
 10 ms
 1 s
 1 s

DISPLAY

000010. MHz
 00010.0 MHz
 0010.00 MHz
 010000. kHz
 10000.0 kHz
 0000.00 kHz
 000.000 kHz

Figure 3-4. Self Check

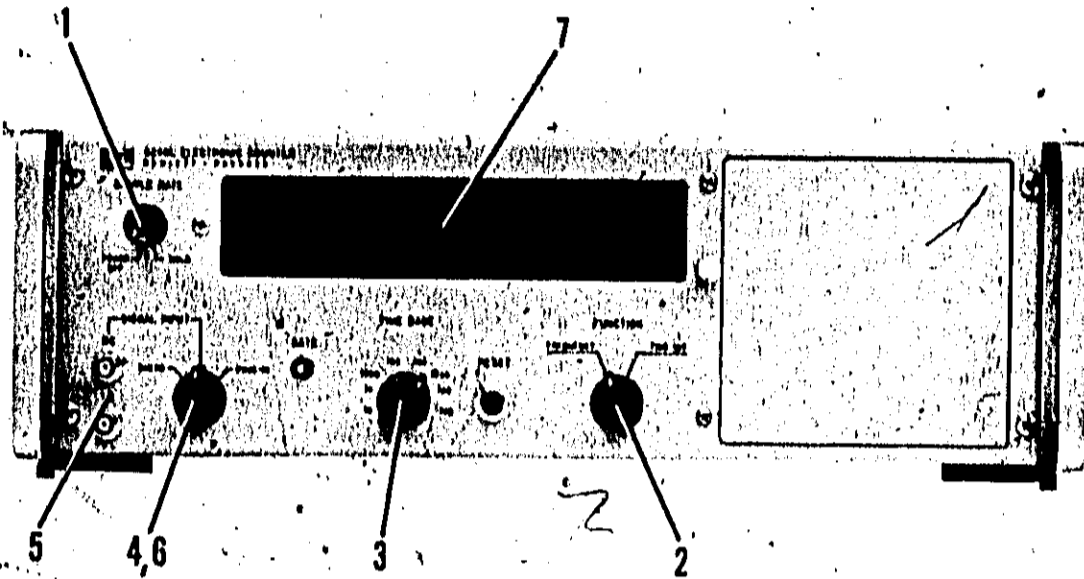

1. Turn SAMPLE RATE control clockwise from POWER OFF position to turn counter on.
2. Set FUNCTION switch to FREQUENCY.
3. Set TIME BASE switch for desired count (gate) time.

Note

Asterisk (*) will light at right end of display for switch positions which do not permit legitimate measurement (in this case EXT and .1 μ S).

4. Set SIGNAL INPUT switch to CHECK to verify proper counter operation (see Figure 3-4).
5. Connect known signal to AC or DC SIGNAL INPUT jack.
6. Switch SIGNAL INPUT switch out of CHECK.
7. Read frequency from display. Decimal point is correctly positioned and correct measurement unit (kHz or MHz) is displayed.

Figure 3-5. Frequency Measurements

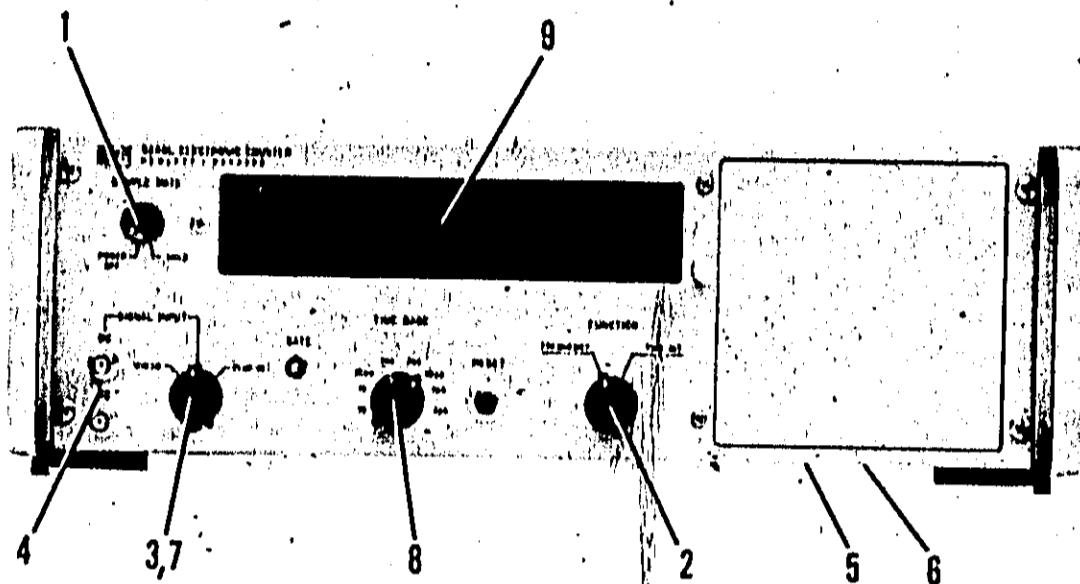

1. Turn counter on with SAMPLE RATE control.
2. Set FUNCTION switch to FREQUENCY.
3. Set SIGNAL INPUT switch to CHECK to verify proper counter operation (see Figure 3-4).
4. Connect f_1 (0 to 50 MHz) to SIGNAL INPUT connector.
5. Connect f_2 (100 Hz to 1 MHz) to STANDARD FREQ jack on rear panel of counter.
6. Set INT/EXT switch to EXT.
7. Set SIGNAL INPUT switch out of CHECK.
8. Multiple ratios can be measured from 10^0 to 10^6 in decade steps by position TIME BASE switch.
9. Read ratio f_1/f_2 from display. Decimal point is correctly positioned but measurement unit is not used since ratio is dimensionless.

Figure 3-6. Frequency Ratio Measurements

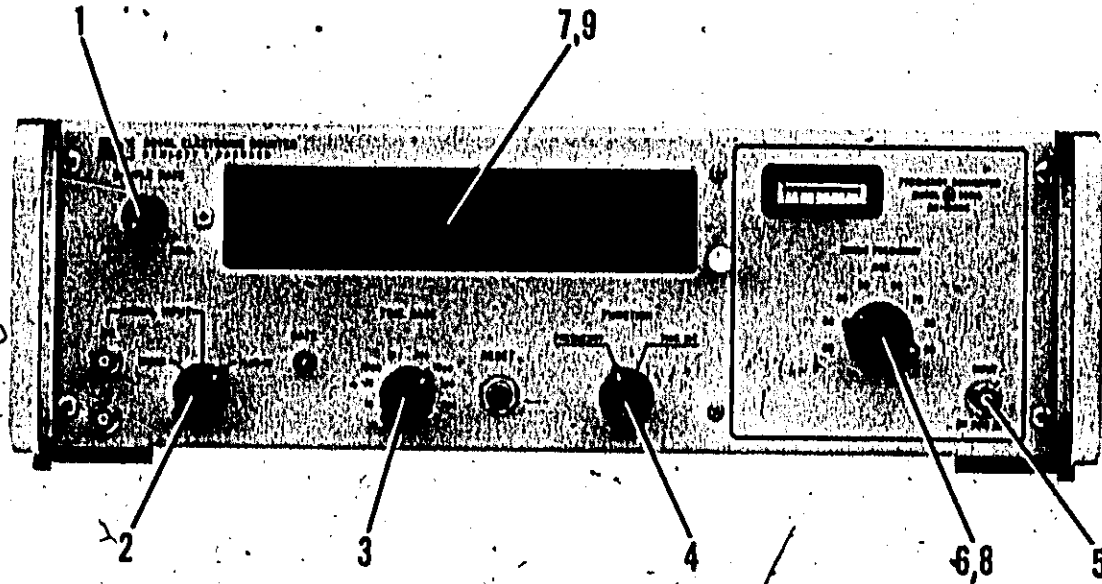

1. Turn SAMPLE RATE control slightly clockwise out of POWER OFF position.
2. Set SIGNAL INPUT switch to PLUG-IN.
3. Set TIME BASE to .1 ms*.
4. Set FUNCTION to FREQUENCY.
5. Connect signal whose frequency is to be measured to converter INPUT. DO NOT EXCEED 2 VOLTS RMS.
6. Set MIXING FREQUENCY to 20 MHz. If meter indicates in green area and counter reading is less than 10 MHz, proceed with step 7 below. If meter does not indicate in green area or if counter reading is greater than 10 MHz, increase MIXING FREQUENCY in 10-MHz

- steps until meter indicates in green area and counter reading is less than 10 MHz.
7. Add counter reading to MIXING FREQUENCY for frequency of INPUT signal.
8. Increase MIXING FREQUENCY by 10 MHz.
9. Subtract counter reading from MIXING FREQUENCY; result should agree with frequency obtained in step 7 above.

Note

Meter may indicate in red area and proper counter reading may not be displayed when MIXING FREQUENCY differs from frequency of INPUT signal by less than 100 kHz. See Table 3-9 when counter reading is between 9.9 MHz and 10.1 MHz.

*TIME BASE setting may vary depending upon desired resolution of INPUT signal frequency. (See Table 3-4.)

Input Freq.	Display	Dial	Meter	Response
EXAMPLE OF ONE RESPONSE				
100.000 MHz	000000 MHz	70 MHz	Red	Difference frequency of 30 MHz is above pass band of video amplifier assembly.
	000000 MHz	80 MHz	Red	Difference frequency of 20 MHz is above pass band of video amplifier assembly.
	010000 MHz	90 MHz	Green	90.000 MHz + 10.000 MHz = 100.000 MHz
EXAMPLE OF TWO RESPONSES				
80.030 MHz	010030 MHz	70 MHz	Green	70.000 MHz + 10.030 MHz = 80.030 MHz
	000000 MHz	80 MHz	Red	Difference frequency of 30 kHz is below pass band of video amplifier assembly.
	009970 MHz	90 MHz	Green	90.000 MHz - 9.970 MHz = 80.030 MHz
EXAMPLE OF TWO RESPONSES				
75.000 MHz	000000 MHz	60 MHz	Red	Difference frequency of 15 MHz is above pass band of video amplifier assembly
	005000 MHz	70 MHz	Green	70.000 MHz + 5.000 MHz = 75.000 MHz
	005000 MHz	80 MHz	Green	80.000 MHz - 5.000 MHz = 75.000 MHz

Figure 3-7. Model 5251A Operating Procedure

3-9. 5251A FREQUENCY CONVERTER.

3-10. The following paragraphs contain information for operating the Model 5251A Frequency Converter plug-in when installed in the Model 5246L Electronic Counter.

3-11. FRONT PANEL.

3-12. **GENERAL.** The functions of the front panel control, meter, and input connector are described in Paragraphs 3-13 through 3-15.

3-13. **INPUT CONNECTOR.** Signal input 50 mV rms (-13 dBm) to 1 V rms (+13 dBm) into type "N" female connector.

3-14. **MIXING FREQUENCY SELECTOR.** Calibrated in megacycles, this control selects a 10 MHz harmonic to be heterodyned with INPUT signal.

3-15. **LEVEL INDICATOR METER.** The meter circuit continuously monitors the level of the difference-frequency signal fed from the converter to the counter. When the meter reads in green portion of the scale, the INPUT signal level is adequate for accurate frequency measurement.

3-16. MAXIMUM INPUT VOLTAGES.

3-17. Damage to the converter may result if an AC signal greater than 2 volts rms or a DC voltage greater than ±100 volts DC is applied to converter INPUT connector.

3-18. OPERATING PROCEDURE.

3-19. Figure 3-7 provides a step-by-step operating procedure to be used for measurement of frequencies from 20 MHz to 100 MHz with INPUT signal amplitudes from 50 mV to 1 V rms.

3-20. When the difference frequency (produced by the heterodyning of the INPUT signal frequency and the selected MIXING FREQUENCY) is less than 100 kHz or more than 12 MHz, change the MIXING FREQUENCY so that the difference frequency is between 100 kHz and 12 MHz (bandwidth of amplifier within the converter). Table 3-4 lists counter displays when INPUT signal frequency is within 100 kHz of a MIXING FREQUENCY.

3-21. TYPICAL FREQUENCY MEASUREMENTS.

3-22. Figure 3-7 shows counter and plug-in indications during three typical frequency measurements.

Table 3-4. Frequency Resolution

TIME BASE SETTING	COUNTER DISPLAY	MEASUREMENT RESOLUTION
.1 μS	(No Display)	
1.0 μS	1 1 . MHz	7 1 . MHz
10.0 μS	1 1 . 1 MHz	7 1 . 1 MHz
.1 MS	1 1 . 1 2 MHz	7 1 . 1 2 MHz
1.0 MS	1 1 1 2 2 . KHz	7 1 . 1 2 2 MHz
10.0 MS	1 1 1 2 2 . 3 KHz	7 1 . 1 2 2 3 MHz
.1 S	1 1 1 2 2 . 3 3 KHz	7 1 . 1 2 2 3 3 MHz
1.0 S	1 1 1 2 2 . 3 3 4 KHz	7 1 . 1 2 2 3 3 4 MHz

INPUT SIGNAL FREQUENCY 71.1223344 MHz MIXER-FREQUENCY DIAL SET TO 60 MHz

Table 3-5. Special Counter Display

Mixer Frequency MHz	Input Frequency MHz								
	2.0 to 20.1	29.9 to 30.1	39.9 to 40.1	49.9 to 50.1	59.9 to 60.1	69.9 to 70.1	79.9 to 80.1	89.9 to 90.1	99.9 to 100
20	*	9.9 to 10.1							
30	9.9 to 10	*	9.9 to 10.1						
40		9.9 to 10.1	*	9.9 to 10.1					
50			9.9 to 10.1	*	9.9 to 10.1				
60				9.9 to 10.1	*	9.9 to 10.1			
70					9.9 to 10.1	*	9.9 to 10.1		
80						9.9 to 10.1	*	9.9 to 10.1	
90							9.9 to 10.1	*	9.9 to 10

*Meter may indicate in red area; counter reading is valid only if meter indication is in green area.

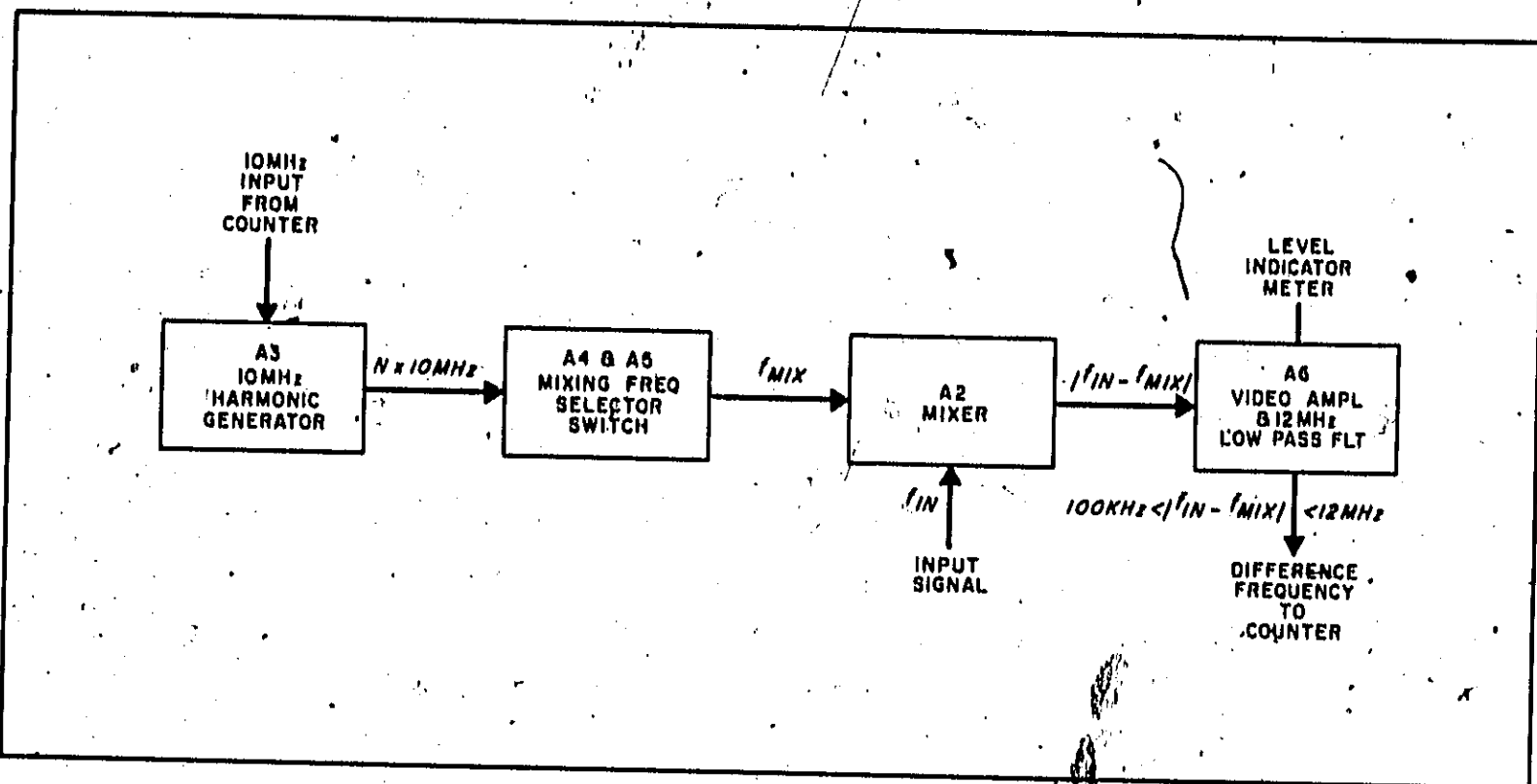
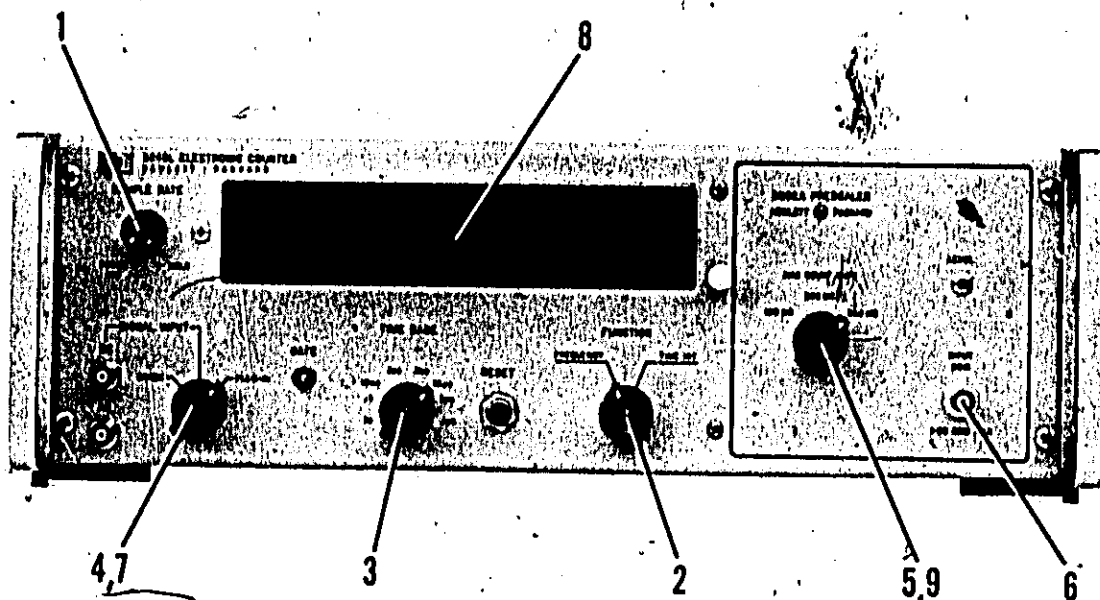

Figure 3-8. Model 5251A Block Diagram



1. Turn counter on with SAMPLE RATE control.
2. Set FUNCTION switch to FREQUENCY.
3. Set TIME BASE switch to desired gate time*.
4. Set SIGNAL INPUT switch to CHECK to verify proper counter operation.
5. Set plug-in MAX COUNT RATE switch to 350 MHz.
6. Connect unknown signal to plug-in INPUT jack.

CAUTION

Input signal must not have any dc voltage and ac signal must not exceed 2 volts rms, +20 dBm, or 100 mw.

7. Set SIGNAL INPUT switch to PLUG-IN.
8. Display is unknown frequency.
9. For faster gate times, the MAX COUNT RATE switch may be set to lower frequency range which includes unknown frequency.

* Gate time is extended by 2:1 when count rate is on 100 MHz; 4:1 when count rate is on 200 MHz, and 8:1 when count rate is on 350 MHz.

Figure 3-9. Model 5252A Operating Procedure

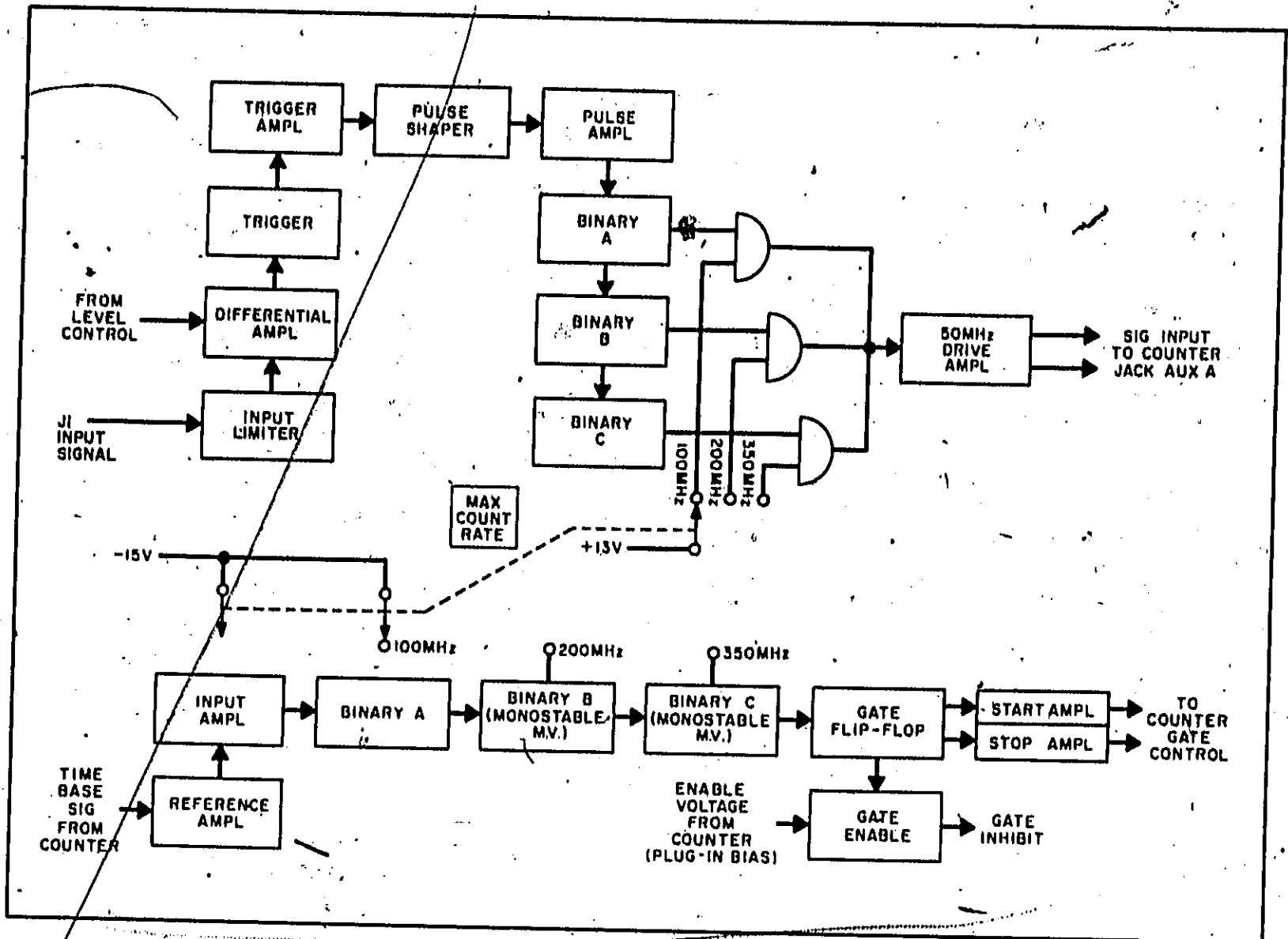

Figure 3-10. Model 5252A Block Diagram

3-23. 5252A PRESCALER.

3-24. The following paragraphs contain information for operating the Model 5252A Prescaler plug-in when installed in the Model 5246L Electronic Counter.

3-25. CONTROLS AND INPUT.

3-26. GENERAL. The function of the front panel switch, connector, and control are described in Paragraphs 3-27 through 3-29.

3-27. MAX COUNT RATE SWITCH. The switch selects scaling factor for the unknown frequencies. The following are the switch positions and their corresponding scaling factors.

MAX COUNT RATE	SCALE FACTOR
100 MHz	2
200 MHz	4
350 MHz	8

3-28. INPUT CONNECTOR. The signal input is DC coupled into 50 ohms. Damage to the plug-in will result if a dc voltage or ac signal greater than 2 V rms, +20 dBm, or 100 mw is applied to the plug-in INPUT connector.

3-29. LEVEL CONTROL. Provides adjustment for counting either positive or negative pulses.

3-30. OPERATING PROCEDURE.

3-31. Figure 3-9 provides a step-by-step procedure for operating the 5252A plug-in.

3-32. 5253B FREQUENCY CONVERTER.

3-33. The following paragraphs contain information for operating the Model 5253B Frequency Converter plug-in when installed in the Model 5246L Electronic Counter.

3-34. FRONT PANEL.

3-35. GENERAL. The functions of the front panel control, meter, and input connector are described in Paragraphs 3-36 through 3-38.

3-36. INPUT CONNECTOR. Signal input, 50 mV (-13 dBm) to 1 V (+13 dBm) into a BNC connector.

3-37. MIXING FREQUENCY SELECTOR. Calibrated in megacycles, this control tunes the internal cavity to select a harmonic of 10 MHz to be heterodyned with the INPUT signal.

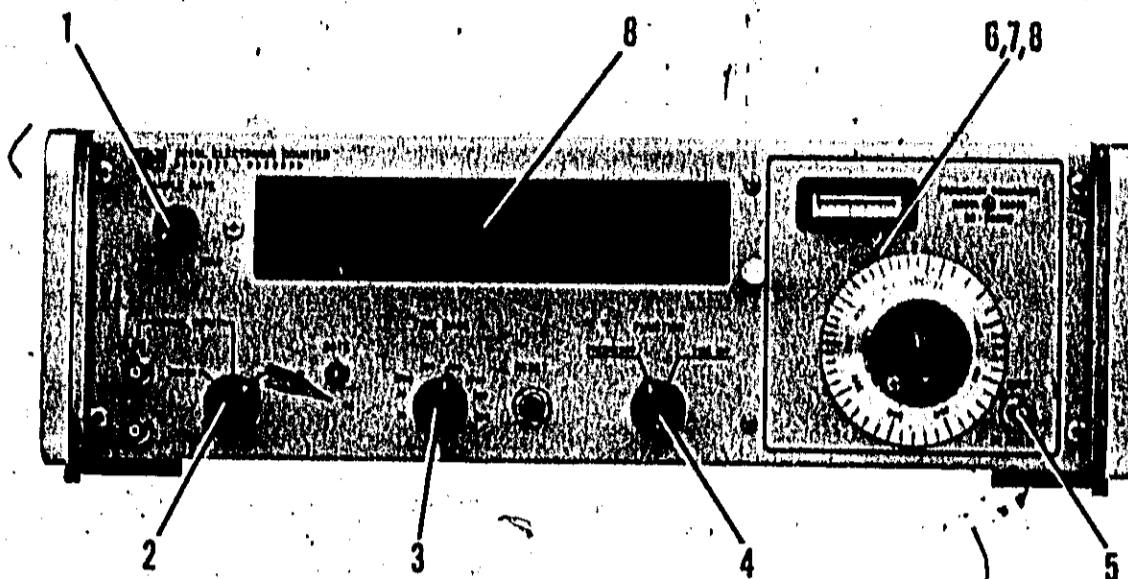

1. Turn SAMPLE RATE control slightly out of POWER OFF position.
2. Set SIGNAL INPUT switch to PLUG-IN.
3. Set TIME-BASE to .1 ms*.
4. Set FUNCTION to FREQUENCY.
5. Connect signal whose frequency is to be measured to INPUT of converter.
6. Set mixing frequency control to read slightly less than 50 MHz.
7. Slowly turn mixing frequency control counter clockwise until level indicator meter first reaches a maximum reading in the green portion of its scale.
8. Add counter display (in MHz) to mixing frequency control reading (in MHz) for frequency of INPUT signal.

* TIME BASE setting may vary, depending on desired resolution of INPUT signal frequency. See Table 3-6.

Input Frequency	Display	Dial	Meter	Response
EXAMPLE OF ONE RESPONSE				
512.000 MHz	000000 MHz	480 MHz	Red	Difference frequency of 32 MHz is above pass band of video amplifier assembly
	000000 MHz	490 MHz	Red	Difference frequency of 22 MHz is above pass band of video amplifier assembly
	012000 MHz	500 MHz	Green	500.000 MHz + 12.000 MHz = 512.000 MHz
EXAMPLE OF TWO RESPONSES				
150.030 MHz	010030 MHz	140 MHz	Green	140.000 MHz + 10.030 MHz = 150.030 MHz
	000000 MHz	150 MHz	Red	Difference frequency of 30 kHz is below passband of video amplifier assembly
	009970 MHz	160 MHz	Green	160.000 MHz - 9.970 MHz = 150.030 MHz
EXAMPLE OF TWO RESPONSES				
155.000 MHz	000000 MHz	140 MHz	Red	Difference frequency of 15 MHz is above pass band of video amplifier assembly
	005000 MHz	150 MHz	Green	150.000 MHz + 5.000 MHz = 155.000 MHz
	005000 MHz	160 MHz	Green	160.000 MHz - 5.000 MHz = 155.000 MHz

Figure 3-11. Model 5253B Operating Procedure

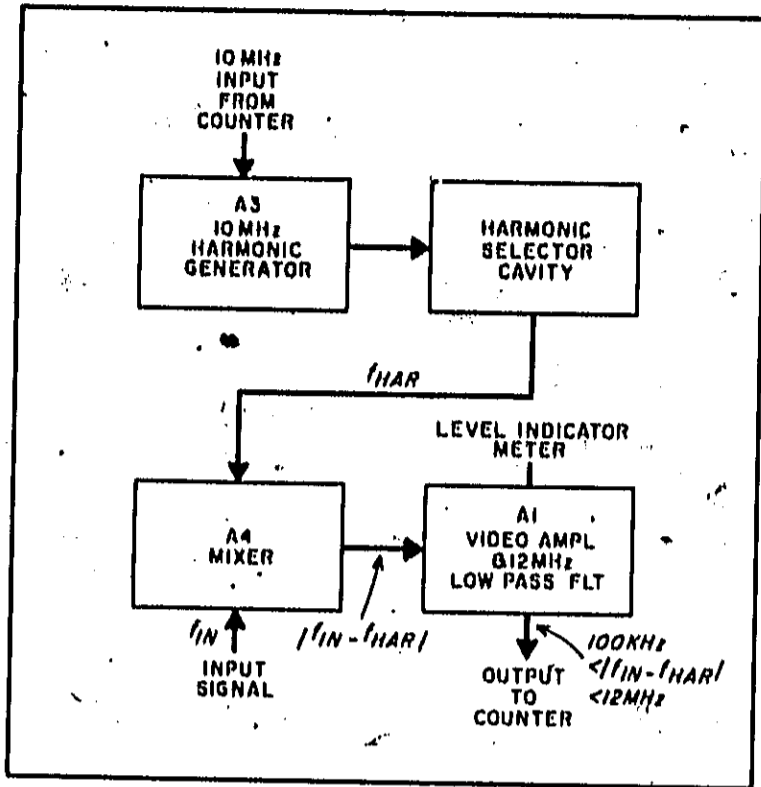

Figure 3-12. Model 5253B Block Diagram

3-38. **LEVEL INDICATOR METER.** The meter circuit continuously monitors the level of the difference-frequency output of the converter to counter. When meter reads in green portion of its scale, INPUT signal amplitude is adequate for accurate frequency measurements.

3-39. **MAXIMUM INPUT VOLTAGES.**

3-40. Damage to the converter may result if an AC signal greater than 2 V rms or a DC voltage greater than 100 V is applied to converter INPUT connector.

3-41. **OPERATING PROCEDURES.**

3-42. **NORMAL RANGE MEASUREMENTS.** Figure 3-11 is the procedure to be used for measurement of frequencies from 50.1 to 512 MHz with INPUT signal amplitudes from 50 mV to 1 V rms.

3-43. **EXTENDED RANGE MEASUREMENTS.** The frequency of signals not within the normal range of 50.1 to 512 MHz, 50 mV to 1 V rms, may be measured using the following procedures:

3-44. 50 TO 50.1 MHz, 50 MV TO 1 V RMS. Perform steps 1 through 5 of Figure 3-11. Then:

- Set mixing frequency control to slightly more than 60 MHz.
- Turn mixing frequency control slowly clockwise until level indicator meter first reaches a maximum reading in the green portion of its scale.
- Subtract counter display (in MHz) from reading of mixing frequency control (in MHz) for frequency of INPUT signal.

3-45. 50 TO 512 MHz, AMPLITUDE LESS THAN 50 MV RMS. The front panel level indicator meter indicates in the green portion of its scale only when converter is properly tuned and amplitude of INPUT signal is adequate for accurate frequency measurement. However, because of conservative specifications of both the converter and counter, frequencies may often be accurately measured when meter reads in the red portion of its scale. To make these extended range measurements:

- Follow normal procedure (Figure 3-11 or Paragraph 3-43, depending upon frequency range) except that mixing frequency control should be tuned for first maximum reading on the level indicator meter, regardless of the color of region maximum.
- Check frequency measurement result as described in Paragraph 3-47, or
- Insert an external variable attenuator (such as Hewlett-Packard Model 355A or 355C) in the transmission line between the converter and the source of INPUT signal. Vary attenuation from 0 to 1 dB during final step of frequency measurement procedure. If counter display does not change more than momentarily (during switching of attenuator), INPUT signal is above noise threshold and frequency measurement result is valid.

3-46. **DOUBLE-CHECKING FREQUENCY MEASUREMENT RESULT.**

3-47. Because of the heterodyne action of the converter, frequency measurement results obtained at any one setting of the mixing frequency control may be checked at other settings. See Figure 3-11 for examples.

Table 3-6. Frequency Measurement

INPUT SIGNAL FREQUENCY = 151.1223344 MHz MIXING FREQUENCY CONTROL set to 140 MHz		
TIME BASE SETTING	COUNTER DISPLAY	MEASUREMENT RESOLUTION
.1 μ s	*(no display)	
1 μ s	1 1 . MHz	1 5 1 . MHz
10 μ s	1 1 . 1 MHz	1 5 1 . 1 MHz
.1 ms	1 1 . 1 2 MHz	1 5 1 . 1 2 MHz
1 ms	1 1 1 2 2 . KHz	1 5 1 . 1 2 2 MHz
10 ms	1 1 1 2 2 . 3 KHz	1 5 1 . 1 2 2 3 MHz
.1 s	1 1 1 2 2 . 3 3 KHz	1 5 1 . 1 2 2 3 3 MHz
1 s	1 1 1 2 2 . 3 3 4 KHz	1 5 1 . 1 2 2 3 3 4 MHz

3-48. 5254B FREQUENCY CONVERTER.

3-49. The following paragraphs contain information for operating the Model 5254B Frequency Converter plug-in when installed in the Model 5246L Electronic Counter.

3-50. The Model 5254B Frequency Converter increases the range of the 5246L Electronic Counter to .2 through 3.0 GHz (200 through 3000 MHz). As a general rule to measure frequency, always start with the Mixing Frequency control below .2 GHz and tune upward in frequency to obtain first response and tune for a maximum reading in the green portion of the meter scale. The input frequency is the sum of the counter reading and the dial frequency reading. This procedure will be valid whether there are responses in 1, 2, or 3 consecutive harmonic reference frequencies; see Figure 3-13. If the input signal level to the converter is high, the second, third and other harmonics of this signal may be generated. Therefore, tuning Mixing Frequency control from the low end upward will enable the input fundamental frequency to be detected before its harmonics. In the 5254B harmonics of the reference-frequency signals are held to such a low level that regardless of input signal level, their mixing effects are not observable, avoiding possible ambiguity. Figure 3-13 provides a step-by-step procedure to be used for measurement of frequencies from .2 to 3.0 GHz (200 MHz to 3000 MHz). The only exception is if the first response occurs at .2 GHz or .25 GHz. To avoid possible ambiguity in these cases, start from above .35 GHz and tune downward in frequency for the first response and subtract the counter reading from the dial frequency for the frequency of the input signal.

NOTE

If the input frequency is known approximately, the Mixing Frequency control can be set a hundred megacycles below the input signal. Tune up for the first response and add the counter reading to the dial frequency.

Table 3-7. Frequency Resolution

INPUT SIGNAL FREQUENCY = 2.4911223344 GHz MIXING FREQUENCY CONTROL set to 2.45 GHz		
TIME BASE SETTING	COUNTER DISPLAY	MEASUREMENT RESOLUTION
.1 μs	*(no display)	
1 μs	4 1 . 1 MHz	2 . 4 9 1 1 GHz
10 μs	4 1 . 1 MHz	2 . 4 9 1 1 GHz
.1 ms	4 1 . 1 2 MHz	2 . 4 9 1 1 2 GHz
1 ms	4 1 1 2 2 KHz	2 . 4 9 1 1 2 2 GHz
10 ms	4 1 1 2 2 . 3 KHz	2 . 4 9 1 1 2 2 3 GHz
.1 s	4 1 1 2 2 . 3 3 KHz	2 . 4 9 1 1 2 2 3 3 GHz
1 s	4 1 1 2 2 . 3 3 4 KHz	2 . 4 9 1 1 2 2 3 3 4 GHz

3-51. CONTROLS AND INPUT.

3-52. GENERAL. The functions of the front panel control, meter, and input connector are described in Paragraphs 3-55 through 3-57.

3-53. INPUT CONNECTOR. Signal input, 50 ohms input impedance, 50 mV (-13 dBm in 50 ohms) to 1 V rms (+13 dBm in 50 ohms) into type "N" female connector.

3-54. MIXING FREQUENCY SELECTOR. Calibrated from .2 to 3.0 GHz (200 MHz to 3000 MHz), this control tunes the internal cavity to select a harmonic of 50 MHz to be heterodyned with the INPUT signal.

3-55. LEVEL INDICATOR METER. The meter circuit continuously monitors the level of the difference-frequency output of the converter to the counter. When meter reads in the green portion of its scale, INPUT signal amplitude is adequate for accurate frequency measurement.

3-56. MAXIMUM INPUT VOLTAGES.

3-57. Damage to the converter may result if an AC signal greater than +20 dBm in 50 ohms (2.2 V rms) or a DC voltage greater than 100 V is applied to converter INPUT connector.

3-58. FREQUENCY MEASUREMENT WITH AMPLITUDE LESS THAN 50 MV RMS.

3-59. The front panel level indicator meter indicates in the green portion of its scale only when converter is properly tuned and amplitude of INPUT signal is adequate for accurate frequency measurement. However, because of conservative specifications of both the converter and counter, frequencies may often be accurately measured when meter reads in the red portion of its scale. To make these extended range measurements:

- Turn SAMPLE RATE control slightly out of POWER OFF position.
- Set SIGNAL INPUT switch to PLUG-IN.
- Set TIME BASE to .1 ms*.
- Set FUNCTION to FREQUENCY.
- Connect signal whose frequency is to be measured to INPUT of converter.
- Set Mixing Frequency Control to read slightly less than .3 GHz.
- Slowly turn Mixing Frequency Control counterclockwise to obtain the first response, and tune for a maximum reading in the green portion of the Level Indicator Meter scale.
- Add Counter display (in MHz) to Mixing Frequency Control reading (in MHz) for frequency of INPUT signal.

*TIME BASE setting may vary, depending on desired resolution of INPUT signal frequency, (see Table 3-4).

Input Freq	Display	Meter	Dial	Response
EXAMPLE OF ONE RESPONSE				
3020 MHz	0000.00 MHz	Red	2.95 Gc (2950 MHz)	No response, difference frequency greater than 1 MHz to 53 MHz pass band of video ampl.
	0020.00 MHz	Green	3.0 Gc (3000 MHz)	First response 3000 MHz + 20 MHz = 3020 MHz
EXAMPLES OF TWO RESPONSES				
1020 MHz	0020.00 MHz	Green	1.0 Gc (1000 MHz)	First response 1000 MHz + 20 MHz = 1020 MHz
	0030.00 MHz	Green	1.05 Gc (1050 MHz)	Second response 1050 MHz - 30 MHz = 1020 MHz
900 MHz	0050.00 MHz	Green	.85 Gc (850 MHz)	First response 850 MHz + 50 MHz = 900 MHz
	0000.00 MHz	Red	.90 Gc (900 MHz)	No response, difference frequency less than 1 MHz to 53 MHz pass band of video amplifier
	0050.00 MHz	Green	.95 Gc (950 MHz)	Second response 950 MHz - 50 MHz = 900 MHz
EXAMPLE OF THREE RESPONSES				
851 MHz	0051.00 MHz	Green	.8 Gc (800 MHz)	First response 800 MHz + 51 MHz = 851 MHz
	0001.00 MHz	Green	.85 Gc (850 MHz)	Second response 850 MHz + 1 MHz = 851 MHz
	0049.00 MHz	Green	.9 Gc (900 MHz)	Third response 900 MHz - 49 MHz = 851 MHz

* Note: Counter in .1 ms Gate to give reading in Megahertz in all examples.

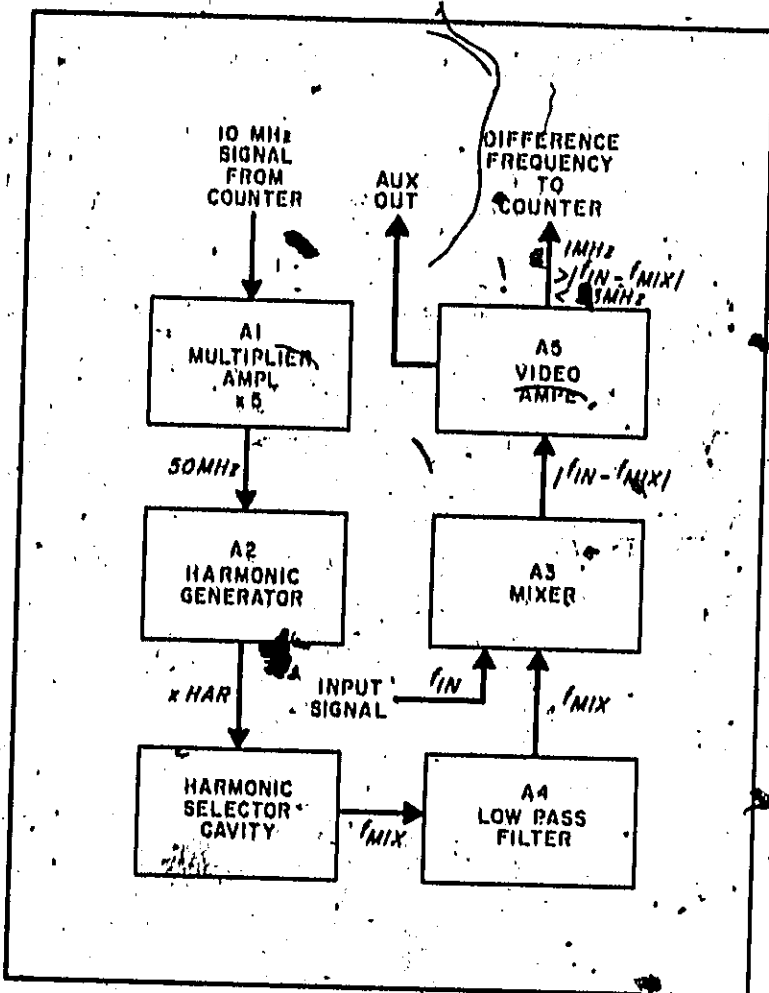

Figure 3-14. Model 5254B Block Diagram

a. Follow normal procedure (Figure 3-13), except that mixing frequency control should be tuned for first maximum reading on the level indicator meter, regardless of the color of region.

b. Check frequency measurement result as described in Paragraph 3-60.

3-60. DOUBLE-CHECKING FREQUENCY MEASUREMENT RESULT.

3-61. Because of the heterodyne action of the converter, frequency measurement results obtained at any one setting of the Mixing Frequency control may

be checked at other settings. In most cases these will be two consecutive responses: tune in the first response and add the counter display to dial frequency reading; then tune up in frequency to the second response and subtract the counter display from the dial frequency reading (see Table 3-8). In some cases there will be three consecutive responses (see Figure 3-13); in these cases the third response will be the one in which you subtract the counter display from the dial frequency reading.

3-62. 5255A FREQUENCY CONVERTER.

3-63. The following paragraphs contain information for operating the Model 5255A Frequency Converter plug-in when installed in the Model 5246L Electronic Counter.

3-64. The Model 5255A Frequency Converter increases the range of the 5246L Electronic Counter to 3 through 12.4 GHz (3000 to 12,400 MHz): As a general rule to measure frequency, always start with the Mixing Frequency control below 3 GHz and tune upward in frequency to obtain first response and tune for a maximum reading in the green portion of the meter scale. This procedure will be valid whether there are responses in 1, 2, or 3 consecutive harmonic reference frequencies; see Figure 3-15. If the input signal level to the converter is high, the second, third, and other harmonics of this signal may be generated. Therefore, tuning Mixing Frequency control from the low end upward will enable the input fundamental frequency to be detected before its harmonics. In the 5255A harmonics of the reference-frequency signals are held to such a low level that regardless of input signal level, their mixing effects are not observable, avoiding possible ambiguity. Figure 3-15 provides a step-by-step procedure to be used for measurement of frequencies from 3 to 12.4 GHz (3000 to 12,400 MHz). The only exception is if the first response occurs at 2.8 GHz or 3.0 GHz. To avoid possible ambiguity in these cases, start from above 3.4 GHz and tune downward in frequency for the first response and subtract the counter reading from the dial frequency for the frequency of the input signal.

Table 3-8. Typical Double-Check Frequency Measurement (5254B)

Input Frequency	Counter Reading*	Mixing Frequency	Meter Indication	Response
1.2345678 GHz	34567.8 kHz	1.2 GHz	Peak	First Response: 1.200000 GHz + 345678 kHz 1.2345678 GHz
	15432.2 kHz	1.25 GHz	Peak	Second Response: 1.250000 GHz - 154322 kHz 1.2345678 GHz

*Note: Counter in 10 ms Gate to give reading in kHz.

3-65 CONTROLS AND INPUTS.

3-66. GENERAL. The function of the front panel tuning control, input connector, meter, AUX input, and AUX output connectors are described in Paragraphs 3-67 through 3-71.

3-67. INPUT CONNECTOR. Signal input, 50 ohms input impedance, 100 mV (-7 dBm in 50 ohms) to 707 mV (+10 dBm in 50 ohms) into precision type "N" female connector (GPC-7 connector is optional). ("N" type male optional.)

3-68. MIXING FREQUENCY SELECTOR. Calibrated from 2.8 GHz to 12.4 GHz (2800 MHz to 12,400 MHz), this control tunes the internal cavity to select a harmonic of 200 MHz to be mixed with the INPUT signal.

3-69. LEVEL INDICATOR METER. The meter circuit continuously monitors the level of the difference-frequency output of the converter to the counter. When meter reads in the green portion of its scale, INPUT signal amplitude is adequate for accurate frequency measurement.

3-70. AUX IN. Signals connected to this input of -33 dBm (5 mV) up to 0 dBm (224 mV) and 1 to 200 MHz at the AUX IN jack will be counted and displayed directly.

3-71. AUX OUT. The output from the AUX OUT jack is the 1 to 200 MHz difference signal from the video amplifier.

NOTE

If any difficulty occurs while making measurements, check all cables and connectors for resonant points.

3-72. MAXIMUM INPUT VOLTAGES.

3-73. Damage to the converter may result if an AC signal greater than +10 dBm (.707 V rms) or a DC voltage greater than 5 V is applied to converter INPUT connector.

3-74. FREQUENCY MEASUREMENT WITH AMPLITUDE LESS THAN 100 MV RMS.

3-75. The front panel level indicator meter indicates in the green portion of its scale only when converter is properly tuned and amplitude of INPUT signal is adequate for accurate frequency measurement. (Because of conservative specifications of the converter this will often occur with an input signal less than 100 mV.)

3-76. DOUBLE-CHECKING FREQUENCY MEASUREMENT RESULTS.

3-77. Because of the heterodyne action of the converter, frequency measurement results obtained at any one setting of the Mixing Frequency control may be checked at other settings. In most cases there will be consecutive responses: tune in the first response and add the counter display to dial frequency reading; then tune up in frequency to the second response and subtract the counter display from the dial frequency reading (see Table 3-9). In some cases there will be three consecutive responses (see Figure 3-15); in these cases the third response will be the one in which you subtract the counter display from the dial frequency reading.

Table 3-9. Typical Double-Check Frequency Measurement (5255A)

Input Frequency	Counter Reading*	Mixing Frequency	Meter Indication	Response
8.1234567 GHz	123456.7 kHz	8.0 GHz	Peak	First Response: 8.000000 GHz + 1234567 kHz 8.1234567 GHz
	76543.3 kHz	8.2 GHz	Peak	Second Response: 8.200000 GHz - 765433 kHz 8.1234567 GHz

* Note: Counter in 10 ms Gate to give readings in kHz.

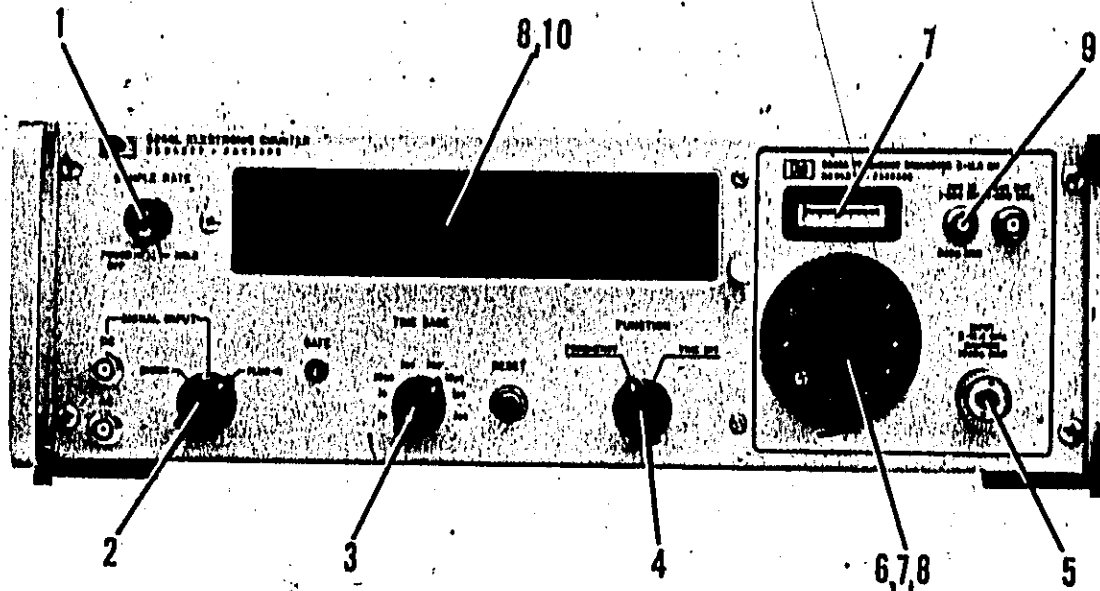

FREQUENCY MEASUREMENTS

1. Turn SAMPLE RATE slightly out of POWER OFF position.
2. Set SIGNAL INPUT switch to PLUG IN.
3. Set TIME BASE to 10 ms. *
4. Set FUNCTION to FREQUENCY.
5. Connect input signal to INPUT of converter.
6. Set Mixing Frequency control to read slightly less than 2.8 GHz.
7. Slowly turn Mixing Frequency control counter-clockwise to obtain the first response, and

*TIME BASE setting may vary, depending on desired resolution of INPUT signal frequency.

tune for a maximum reading in the green portion of the Level Indicator Meter scale.

8. Add counter display (in kHz) to Mixing Frequency control reading (in GHz) for frequency of INPUT signal.

USE OF AUX IN

9. To use prescaler portion of plug-in connect the 1 to 200 MHz input signal to the AUX IN jack (0 dBm max).
10. The counter will display frequency of input signal. (During this measurement the main input to the converter should be disconnected, or, if a microwave signal is present at the main input, the converter should be detuned so that there is no counter reading from that source).

Figure 3-15. Model 5255A Operating Procedure

Table 3-10: Model 5255A Typical Frequency Measurements

INPUT FREQUENCY	DISPLAY	METER	DIAL	RESPONSE
EXAMPLE OF ONE RESPONSE				
2800 MHz	0000.00 MHz	Red	3.0 GHz	No response; frequency difference greater than passband of video amplifier
	0200.00 MHz	Green	2.8 GHz	First Response: $\begin{matrix} 2800 \text{ MHz} \\ - 200 \text{ MHz} \\ \hline 2600 \text{ MHz} \end{matrix}$
12,600 MHz	0000.00 MHz	Red	12.2 GHz	No response; frequency difference greater than passband of video amplifier
	0200.00 MHz	Green	12.4 GHz	First Response: $\begin{matrix} 12,400 \text{ MHz} \\ + 200 \text{ MHz} \\ \hline 12,600 \text{ MHz} \end{matrix}$
EXAMPLE OF TWO RESPONSES				
10,050 MHz	0050.00 MHz	Green	10.0 GHz	First Response: $\begin{matrix} 10,000 \text{ MHz} \\ + 50 \text{ MHz} \\ \hline 10,050 \text{ MHz} \end{matrix}$
	0150.00 MHz	Green	10.2 GHz	Second Response: $\begin{matrix} 10,200 \text{ MHz} \\ - 150 \text{ MHz} \\ \hline 10,050 \text{ MHz} \end{matrix}$
4,000 MHz	0200.00 MHz	Green	3.8 GHz	First Response: $\begin{matrix} 3,800 \text{ MHz} \\ + 200 \text{ MHz} \\ \hline 4,000 \text{ MHz} \end{matrix}$
	0000.00 MHz	Red	4.0 GHz	No response; difference frequency less than passband of video amplifier
	0200.00 MHz	Green	4.2 GHz	Second Response: $\begin{matrix} 4,200 \text{ MHz} \\ - 200 \text{ MHz} \\ \hline 4,000 \text{ MHz} \end{matrix}$
EXAMPLE OF THREE RESPONSES				
11,005 MHz	0205.00 MHz	Green	10.8 GHz	First Response: $\begin{matrix} 10,800 \text{ MHz} \\ + 205 \text{ MHz} \\ \hline 11,005 \text{ MHz} \end{matrix}$
	0005.00 MHz	Green	11.0 GHz	Second Response: $\begin{matrix} 11,000 \text{ MHz} \\ + 5 \text{ MHz} \\ \hline 11,005 \text{ MHz} \end{matrix}$
	0195.00 MHz	Green	11.2 GHz	Third Response: $\begin{matrix} 11,200 \text{ MHz} \\ - 195 \text{ MHz} \\ \hline 11,005 \text{ MHz} \end{matrix}$
<p>*When response present at 2.8 or 3.0 GHz, tune from above and subtract first reading, (See Paragraph 3-64)</p>				

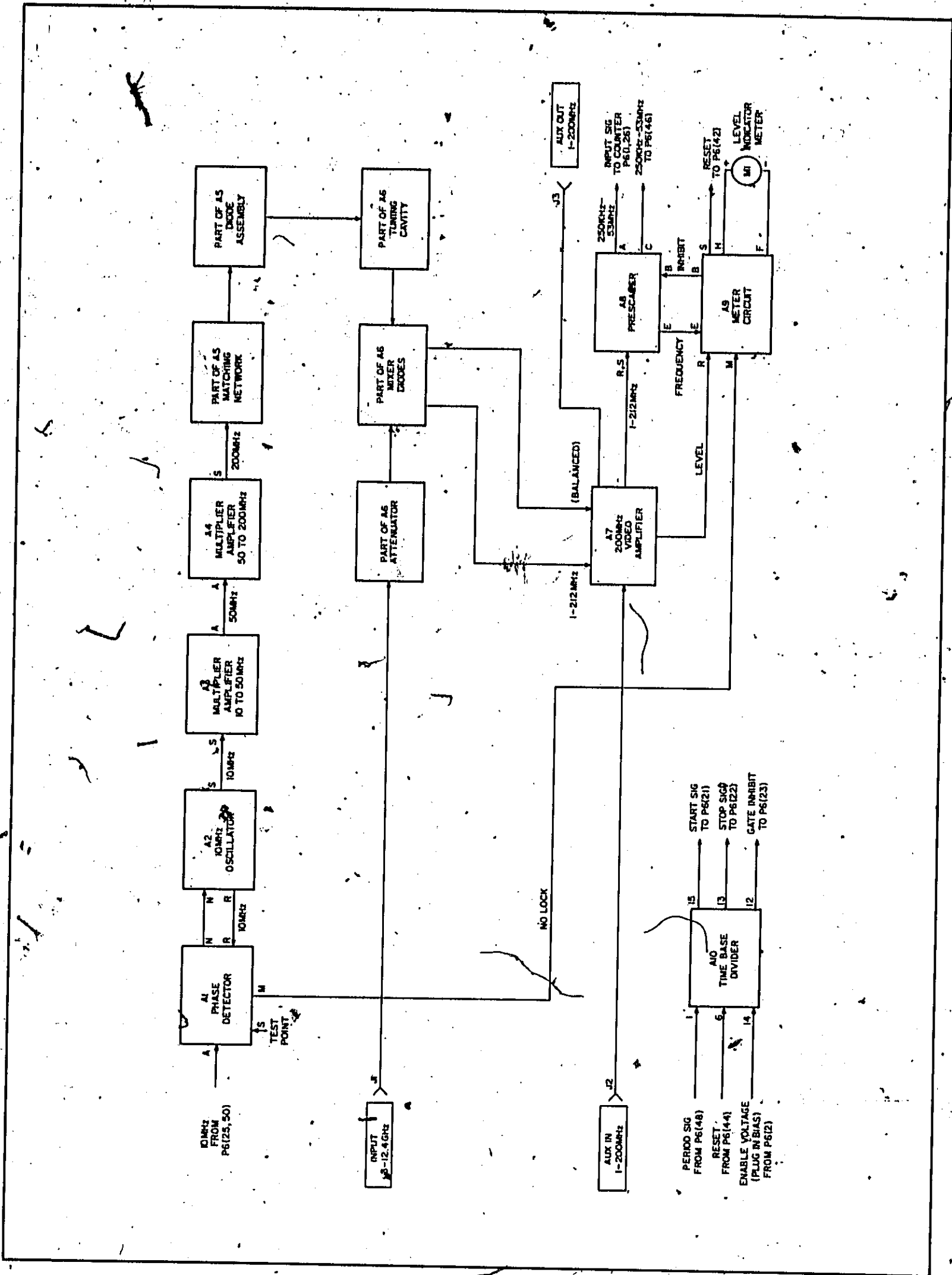
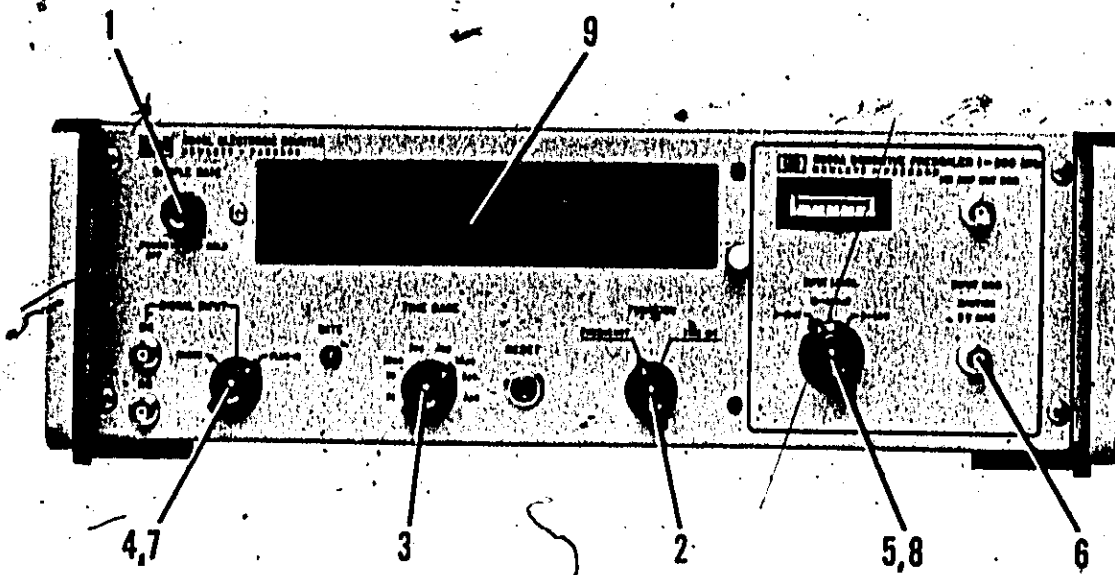

Figure 3-16. Model 5255A Block Diagram



1. Turn counter on with SAMPLE RATE control.
2. Set FUNCTION switch to FREQUENCY.
3. Set TIME BASE switch to desired gate time*.
4. Set SIGNAL INPUT switch to CHECK to verify proper counter operation.
5. Set plug-in INPUT LEVEL switch to 1 volt range.
6. Connect unknown signal to plug-in INPUT jack.
7. Set SIGNAL INPUT switch to PLUG-IN.
8. Adjust INPUT LEVEL switch until constant count appears.
9. Display is unknown frequency.

* When using HP Model 5258A Sensitive Pre-scaler, the gate time of the counter is extended by a factor of four.

Figure 3-17. Model 5258A Operating Procedure

3-78. 5258A SENSITIVE PRESCALER.

3-79. The following paragraphs contain information for operating the Model 5258A Sensitive Prescaler plug-in when installed in the Model 5246L Electronic Counter.

3-80. The Model 5258A Sensitive Prescaler plug-in increases the range of the 5246L Electronic Counter to 200 MHz. It also increases the sensitivity of the counter to 1 mV from 1 MHz to 200 MHz. Input frequency prescaling (dividing) is accomplished by transistor binary dividers operating over the frequency range from 1 MHz to 200 MHz. At the same time, the prescaler adjusts the counter's time base an equal amount to provide direct readout in frequency.

3-81. The input signal is applied to a broadband amplifier and tunnel diode trigger prior to reaching the transistor binary dividers. The circuitry is stable and independent of frequency, so no adjustments are needed over the entire frequency range. An attenuator switch on the front panel enables the prescaler to be used with inputs over the range of 1 mV to 1 V. The output of the video amplifier is available at the video output connector located on the front panel of the plug-in. An oscilloscope may be used to monitor the unknown signal being measured. A front panel meter indicates a deflection in the green area when adequate voltage is present at the input. The counter is inhibited if the unknown signal is not adequate to operate the counter.

3-82. FRONT PANEL.

3-83. **GENERAL.** The function of the front panel switch, meter, and connectors are described in Paragraphs 3-84 through 3-87.

3-84. **INPUT LEVEL SWITCH.** The input level switch provides three ranges of input sensitivity to the prescaler. They are 1-10 mV, 10-200 mV, and 0.2-1.0 volts.

3-85. **LEVEL INDICATOR METER.** The meter circuit continuously monitors the level of the input signal to the prescaler. When meter reads in green portion of its scale, input signal amplitude is adequate for accurate frequency measurements.

3-86. **INPUT CONNECTOR.** Signal input, 1 mV (-47 dBm) to 1 volt (+13 dBm) into a BNC connector.

3-87. **VIDEO AMPLIFIER OUTPUT.** The video amplifier has a maximum gain of 30 dB when the input level switch is on the 1 mV level setting. This provides an output of approximately 30 mV.

3-88. MAXIMUM INPUT VOLTAGES.

3-89. Damage to the plug-in may result if an AC signal greater than 3 volts rms or a DC voltage greater than 100 volts is applied to the plug-in input connector.

3-90. OPERATING PROCEDURE.

3-91. Figure 3-17 provides a step-by-step procedure for operating the 5258A plug-in.

3-22

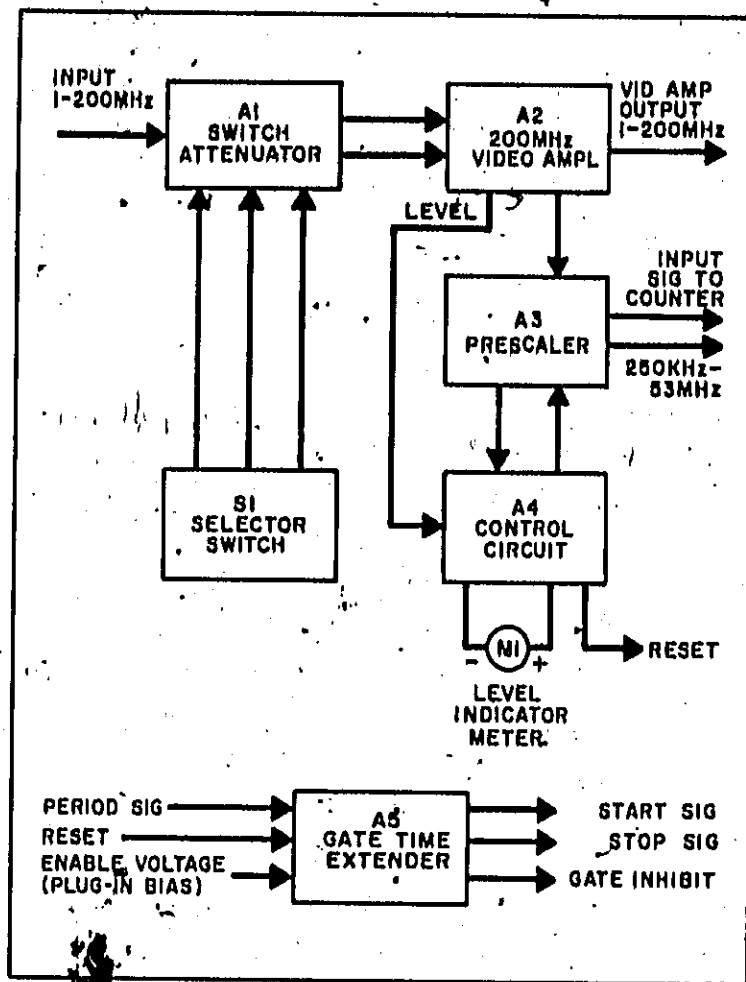

Figure 3-18. Model 5258A Block Diagram

3-92. 5261A VIDEO AMPLIFIER.

3-93. The following paragraphs contain information for operating the Model 5261A Video Amplifier plug-in when installed in the Model 5246L Electronic Counter.

3-94. FRONT PANEL.

3-95. **GENERAL.** The functions of the front panel control, meter, and connectors are described in Paragraphs 3-96 through 3-99.

3-96. **INPUT CONNECTOR.** Input signal 1 to 100 mV rms from 10 Hz to 50 MHz.

3-97. **SENSITIVITY CONTROL.** Calibrated in millivolts, this control determines the sensitivity of the Video Amplifier and is adjusted to keep the signal output to the Counter within limits acceptable to the Counter input circuit as indicated on the OUTPUT LEVEL meter.

3-98. **OUTPUT LEVEL METER.** The meter monitors the level of the Video Amplifier output to the counter. When meter indicates in green portion of scale, Video Amplifier output to counter is satisfactory.

3-99. **OUTPUT 50Ω CONNECTOR.** When terminated in 50 ohms, the signal at this connector is identical in frequency and amplitude to the Video Amplifier output to the counter.

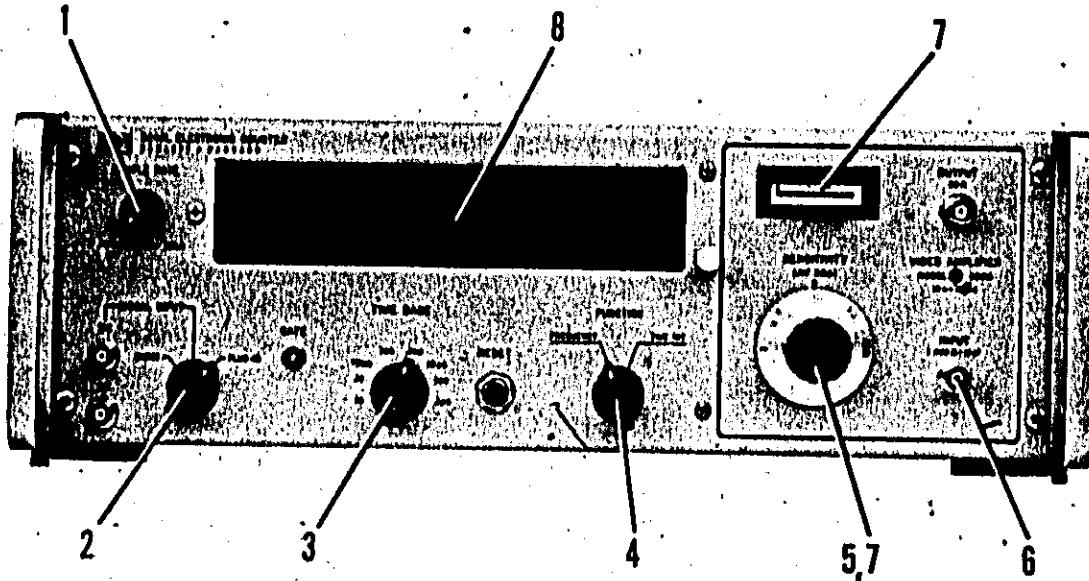

1. Apply power to Counter and Video Amplifier by turning SAMPLE RATE control slightly clockwise from POWER OFF position.
2. Set Counter SIGNAL INPUT switch to PLUG-IN.
3. Set TIME BASE to 10 ms*.
4. Set FUNCTION to FREQUENCY.
5. Set Video Amplifier SENSITIVITY to 100 MV.
6. Connect signal to be measured to INPUT connector on Video Amplifier. DO NOT EXCEED 5 VOLTS RMS.
7. Vary SENSITIVITY control until OUTPUT LEVEL meter reads in green portion of scale.
8. Observe frequency of INPUT signal as displayed by Counter.

* TIME BASE setting may vary depending upon desired resolution of INPUT signal frequency (Table 3-11).

Figure 3-19. Model 5261A Operating Procedure

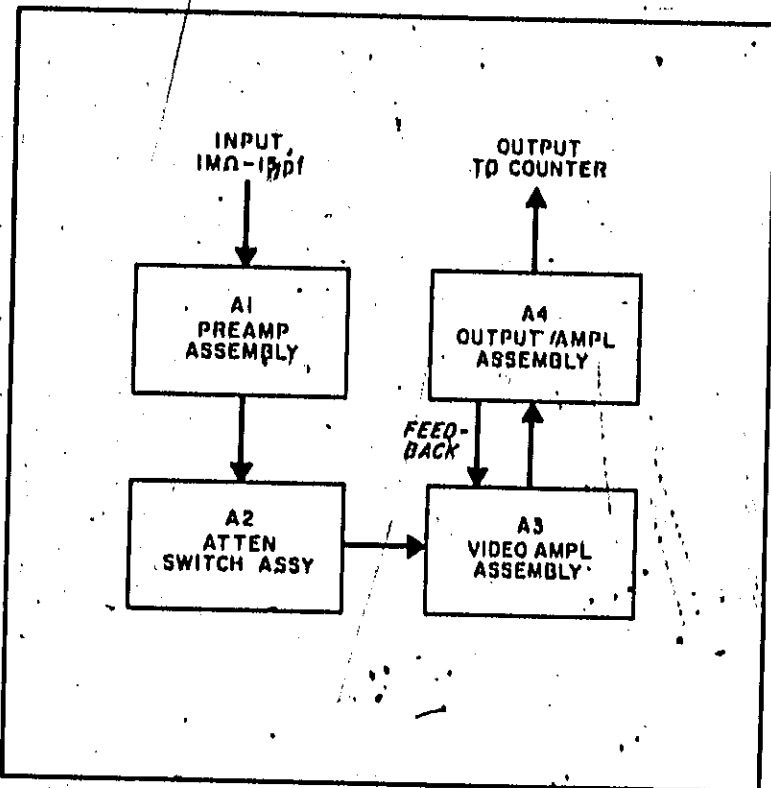

Figure 3-20. Model 5261A Block Diagram

3-106. VIDEO AMPLIFIER INPUT IMPEDANCE.

3-107. As illustrated in Figure 3-21, Video Amplifier input impedance decreases at higher frequencies. This decrease is due to the capacitive loading effect of the amplifier input. Thus when a signal source of fixed impedance is connected to the Video Amplifier INPUT, a meter at the signal source will not indicate the correct input level at the Video Amplifier. To avoid this error, monitor the input level at the Video Amplifier input with an RF Voltmeter such as the Model 411A to ensure a satisfactory input level. The Video Amplifier input can also be terminated in the signal source characteristic impedance but at frequencies near 50 MHz capacitive loading reduces the input impedance, the signal source is no longer terminated in its characteristic impedance, and a meter at the signal source is incorrect. Thus, the simplest method of ensuring a satisfactory input to the Video Amplifier is to monitor the signal level at the Video Amplifier input.

Table 3-11. Frequency Resolution

INPUT FREQUENCY = 11.1223344 MHz	
TIME BASE Setting	Counter Display and Resolution
.1 μs	no display
1 μs	11. MHz
10 μs	11.1 MHz
.1 ms	11.12 MHz
1 ms	11122. kHz
10 ms	11122.3 kHz
.1 s	11122.33 kHz
1 s	11122.334 kHz

3-100. OPERATING PROCEDURE:

3-101. The Video Amplifier plug-in unit is ac-coupled but does not change any functions of the counter in which it is installed. Using the plug-in, period, multiperiod, frequency, totalizing, and ratio measurements can be performed with input signals as low as one millivolt. Since the measurements can be made with or without the Video Amplifier installed, only frequency measurement is illustrated in Figure 3-00. For other measurement procedures, see the Operating Procedures (Figures 3-0 through 3-0) for Counter. Table 3-00 lists the frequency resolution for all settings of the counter TIME BASE control (Figure 3-00, item 4).

3-102. OPERATION WITH PULSE INPUT SIGNALS.

3-103. The Video Amplifier is designed to amplify sinusoidal input signals. However, pulse input signals can be amplified if the output signal is monitored to ensure a satisfactory output to the counter. Monitor the signal at the OUTPUT 50Ω connector with an oscilloscope and set the Video Amplifier SENSITIVITY control for a level which results in satisfactory counter operation. Because the output level meter is an average-responding device, it will read low with a pulse input signal. Do not use the meter as an output level indicator when amplifying pulses.

3-104. OPERATION WITH HIGH IMPEDANCE PROBE.

3-105. The 10003A 10:1 divider probe can be used with the Video Amplifier. The 10:1 divider probe serves to decrease the effects of resistive loading on the external circuit at low frequencies. When using the probe, Video Amplifier sensitivity is decreased by 1/10. As a result, the maximum sensitivity of the Video Amplifier is 10 mV.

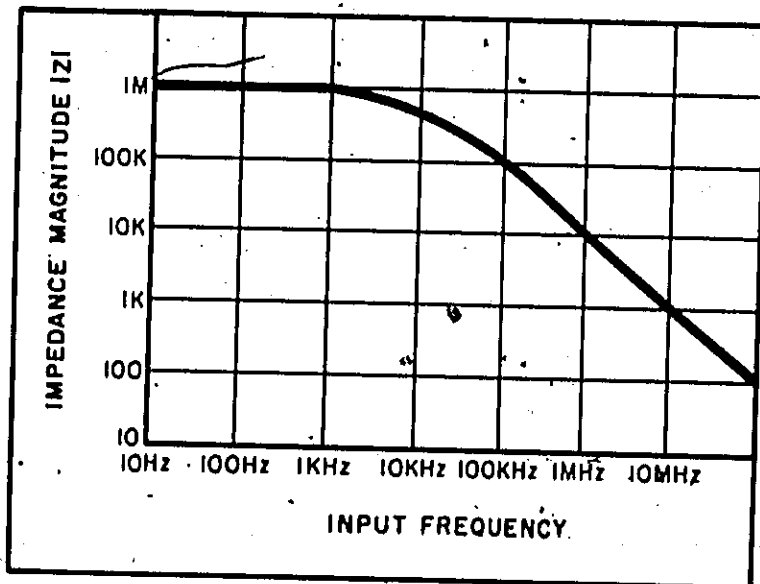

Figure 3-21. Model 5261A Input Impedance.

3-108. 5262A TIME INTERVAL UNIT.

3-109. The following paragraphs contain information for operating the HP Model 5262A Time Interval Unit plug-in when installed in the HP Model 5246L Electronic Counter.

3-110. The Model 5262A has two independent channels which determine the beginning and the end of a time interval. Each channel has its own TRIGGER SLOPE, TRIGGER LEVEL, and MULTIPLIER controls. Figures 3-24 and 3-25 show procedures for making a time interval measurement and a phase measurement. The following paragraphs describe the function of each control.

3-111. CONTROLS.

3-112. **FUNCTION SWITCH.** The function switch provides the operator with three modes of operation: common, separate, and remote.

a. With the function switch in the COMMON position START and STOP input connectors are connected together internally. Thus, if start and stop signals come from the same source, set function switch to COMMON and apply the signal to either input connector. Adjust MULTIPLIER and TRIGGER LEVEL controls for each channel separately.

b. With the function switch in the REMOTE position, the time interval function becomes one of the remote programming operations of the counter.

c. With the function switch in the SEPARATE position the start signal must be applied to START input connector and stop signal must be applied to STOP input connector.

3-113. **TRIGGER SLOPE.** The TRIGGER SLOPE controls determine the slope a signal must have as it crosses the voltage level set by the MULTIPLIER and TRIGGER LEVEL controls to start or stop a measurement.

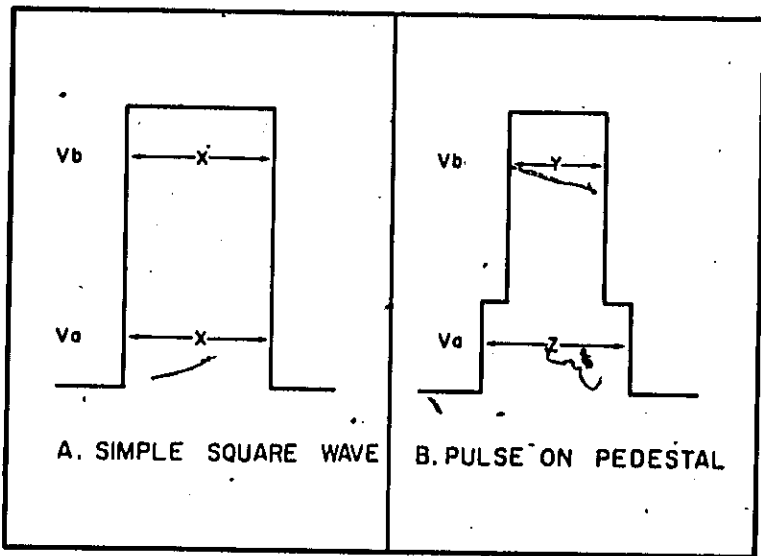

Figure 3-22. Model 5262A Trigger Level Settings

3-114. **MULTIPLIER AND TRIGGER LEVEL.** These controls work together to determine the voltage level a signal must cross to start or stop a measurement. For example with the TRIGGER LEVEL dial set at +2 and the MULTIPLIER set at .3 the Model 5262A will trigger as the input crosses the +0.6 volt level. Suppose you have a pulse as shown in Figure 3-22A, there will be little difference whether measurement begins at V_H or V_L . However, to measure internal "y" of Figure 3-22B, you must be more careful. Set TRIGGER LEVEL dial reading near 0 as a preliminary adjustment. Adjust the start and then the stop TRIGGER LEVEL controls. Watch for definite changes in measured time. Thus you know that start and stop voltage levels are above the step and that the indicated time interval is actually "y".

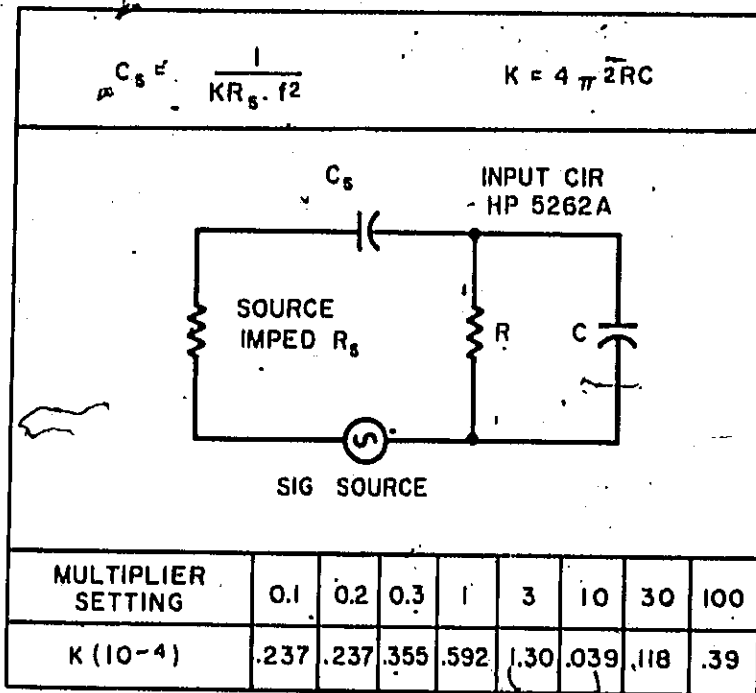

Figure 3-23. Remove DC from Sine Wave Input

3-115. ELIMINATING DC COMPONENT FROM SINE WAVE INPUT.

3-116. As the input circuits of the Model 5262A are dc coupled it is sometimes easier to set the MULTIPLIER and TRIGGER LEVEL controls when any dc component from the start and/or stop sine wave input signals is eliminated with blocking capacitors. With the aid of Figure 3-23 you can select the proper value of blocking capacitor for no readout error. For example, on the .1 MULTIPLIER range, at 400 Hz and with a source impedance of 10,000 ohms the proper value of blocking capacitor is 25 μ f.

3-117. However, if the right value of capacitor is not available, use the following approximate formula to determine what the error per channel in seconds will be (for phase shifts less than 10⁰ and signals less than ± 40 volts peak times multiplier position):

$$\text{Error in seconds} = \frac{1}{C_s (R_s + R) (2 \pi f)^2} + \frac{R_s (RC)}{R_s + R}$$

C_s = Blocking capacitor

R_s = Signal source impedance

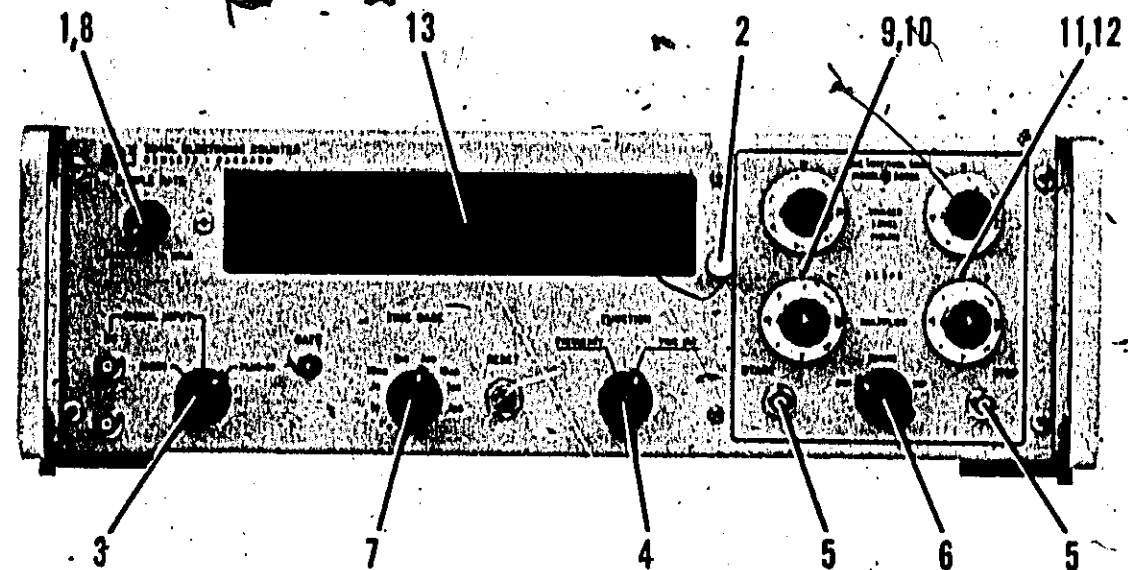

1. Turn SAMPLE RATE control to POWER OFF.
2. Plug in Model 5262A, turning knurled knob clockwise until tight.
3. Set SIGNAL INPUT switch to PLUG-IN.
4. Set FUNCTION switch to TIME INT.
5. Connect signal to START or STOP with selector at common, to START and STOP at other positions of selector switch.
6. Set COM-REMOTE-SEP to:
 - a. COM if start and stop signals are from same source.
 - REMOTE if the Model 5245L is being operated from a remote control box.
 - SEP if start and stop signals are from different sources.
7. Set TIME BASE switch to obtain greatest possible count.
8. Set SAMPLE RATE control for desired operating rate.
9. Set start channel SLOPE control to "+" if you want measurement to stop on positive-going part of signal. Set to "-" if you want to stop count on negative slope.
10. Adjust stop MULTIPLIER and TRIGGER LEVEL controls to set measurement start points at desired voltage level.
11. Set stop channel SLOPE control to "+" if you want measurement to stop on positive-going part of signal. Set to "-" if you want to stop count on negative slope.
12. Adjust stop MULTIPLIER and TRIGGER LEVEL controls to set measurement stop points at desired voltage level.
13. Read time interval units.

Figure 3-24. Model 5262A Operating Procedure

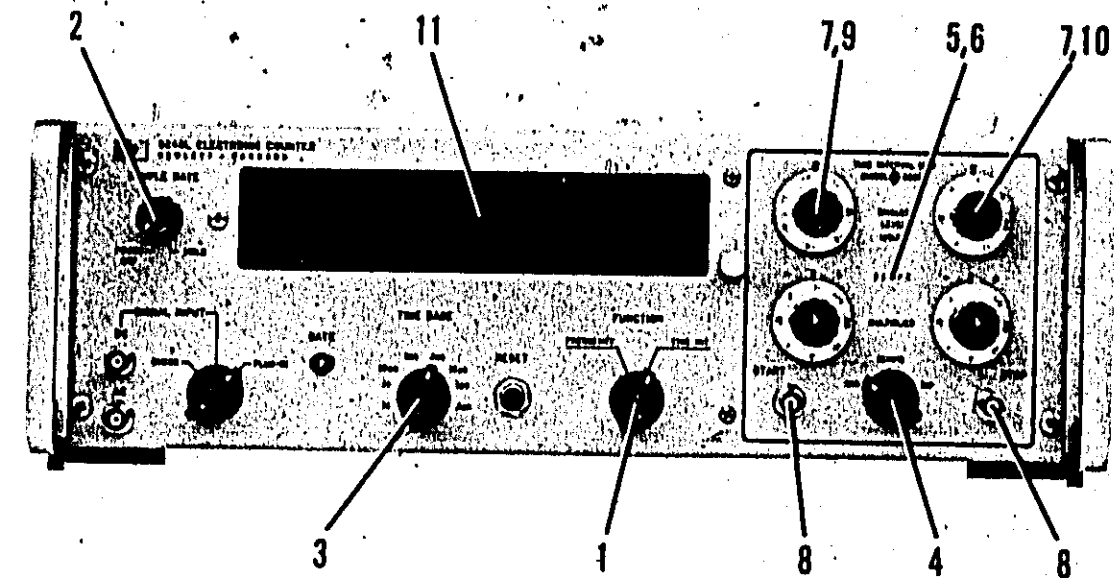

1. Set FUNCTION to TIME INT.
2. Set SAMPLE RATE to position just before POWER OFF. (MAX SAMPLE RATE.)
3. Set TIME BASE switch to obtain greatest possible count.
4. Set COM-REMOTE-SEP to SEP.
5. Set start and stop TRIGGER SLOPE to same polarity.
6. Set both START and STOP MULTIPLIER controls to 0.1 position.
7. Set both start and stop TRIGGER LEVEL controls to 0 position.
8. Connect signals whose phase difference is to be measured to START and STOP inputs. (Note: For specified accuracy, do not exceed ± 40 volts peak times multiplier setting.)
9. Set start TRIGGER LEVEL control for no difference in counter reading as state MULTIPLIER is switched between the 0.1 and 0.2 positions. Procedure:
 - a. Note counter reading with MULTIPLIER set to 0.1 position.
 - b. Note counter reading with MULTIPLIER set to 0.2 position.
 - c. Subtract the smaller reading from the larger reading.
 - d. If reading in step b is less than reading in step a, add result of step c to reading step a and adjust TRIGGER LEVEL for result.
 - e. If reading in step b is greater than reading in step a, subtract result of step c from reading of step a and adjust TRIGGER LEVEL for result.
10. Repeat step 9 for stop TRIGGER LEVEL control.
11. Read phase difference in units selected by TIME BASE switch.

Note

The procedure may have to be repeated to obtain exact zero crossing.

Figure 3-25. Model 5262A Operating Procedure Phase Measurements

RC = 6×10^{-7} for 0.1 and 0.2 MULTIPLIER settings,
 0×10^{-7} for 0.3, 1.5×10^{-6} for 1,
 3.3×10^{-6} for 3, 1×10^{-5} for 10,
 3×10^{-5} for 30, 1×10^{-4} for 100.

3-118. For example, on the .1 MULTIPLIER range, the use of a $10 \mu\text{f}$ blocking capacitor at 400 Hz and with a source impedance of 600 ohms results in an error of 1.5 microseconds.

3-119. PHASE MEASUREMENT.

3-120. Phase measurement is a special application of time interval measurement. You measure the time interval between like points on two similar waveforms and relate the reading to phase angle. The measurement is made between the points where the signals cross 0 volt going in the same direction. The zero-crossing is the reference point for two reasons: first, it is the easiest point to determine accurately on the counter, and second, for sine waves it is in the region of maximum slope, allowing maximum resolution.

3-121. Phase difference is measured in time units if one of the internal standard frequencies is counted. The following formula converts time interval (t) to phase (ϕ) in degrees:

$$\phi = \frac{360t}{\text{period of either signal}}$$

3-122. If the two signals are not equal in amplitude, use the larger for the period measurement. You can measure phase directly in degrees if you apply the appropriate external frequency ($360 \times$ frequency of signals whose phase you are measuring) to the counters in place of an internal standard frequency. However, the external frequency cannot exceed the maximum counting rate of the instrument. Procedure for phase measurement is given in Figure 3-25.

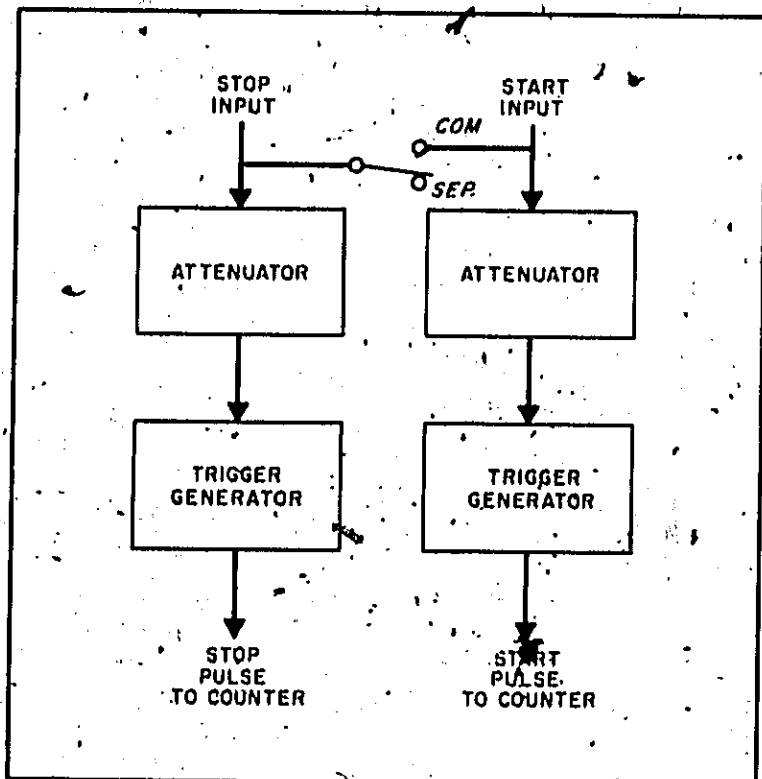

Figure 3-26. Model 5262A Block Diagram

3-123. 5264A PRESET UNIT.

3-124. The following paragraphs contain information for operating the Model 5264A Preset Unit plug-in when installed in Model 5246L Electronic Counter.

3-125. FRONT PANEL.

3-126. The functions of the front panel switches and connectors are as follows:

a. N switches permit selection of gate times.

b. MODE SELECTOR.

1. N x FREQ permits direct or normalized measurement of the input signals, whereby normalization may be accomplished by adjusting the number of signals to be counted or by counting signals for a predetermined time. The display may then be read out in desired units.

2. PRESET permits counting N events when N is set on thumbwheel switches.

3. f/N permits division of any input frequency up to 100 kHz by N.

c. AUX INPUT is used for PRESET and f/N functions.

d. f/N OUTPUT provides a means of using the divided signal with external equipment.

3-127. ACCURACY.

3-128. N x FREQ accuracy is ± 1 count \pm time base accuracy.

3-129. OPERATING PROCEDURE.

3-130. Figures 3-27 through 3-29 provide step-by-step operating procedures to be used for the different functions of the Model 5264A plug-in.

3-131. OUTPUT VOLTAGE.

3-132. The output voltage at the f/N output is normally negative 0.2 volts p/p pulse with an internal impedance of approximately 50 ohms. The minimum load resistance should not be less than 100 ohms and/or maximum shunt capacity be greater than $0.01 \mu\text{f}$. A -5 volt peak pulse with an internal impedance of approximately 600 ohms is available by changing the wire from J2 at XA4 Pin 13 to XA4 Pin 14. If the -5 volt pulse is used, the minimum load resistance should not be less than 10K ohms and/or maximum shunt capacity be greater than 1000 pF.

NOTE

If the -5 volt pulse is used, care should be taken not to short out the f/N signal as this will cause the counter to stop working until the short is removed.

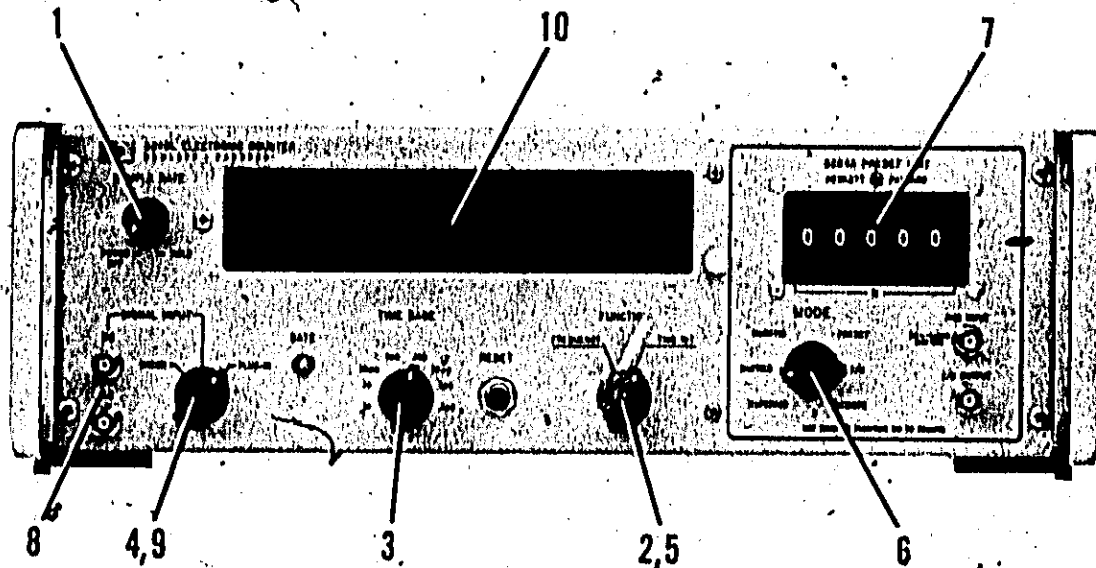

1. Turn counter on with SAMPLE RATE control.
2. Set FUNCTION switch to FREQUENCY.
3. Set TIME BASE switch to desired time unit per count.
4. Set SIGNAL INPUT switch to CHECK to verify proper counter operation.
5. Set counter FUNCTION switch to TIME INTERVAL.
6. Set plug-in MODE switch to N x FREQ.
7. Set N switch for number of time base units to be counted. Time base units are now time base increments. Gate length will be N increments of time.
8. Connect unknown signal to AC or DC SIGNAL INPUT jack.
9. Turn SIGNAL INPUT switch out of CHECK.
10. Display is number of events in count time.

Figure 3-27, Model 5264A Operating Procedure N x FREQ

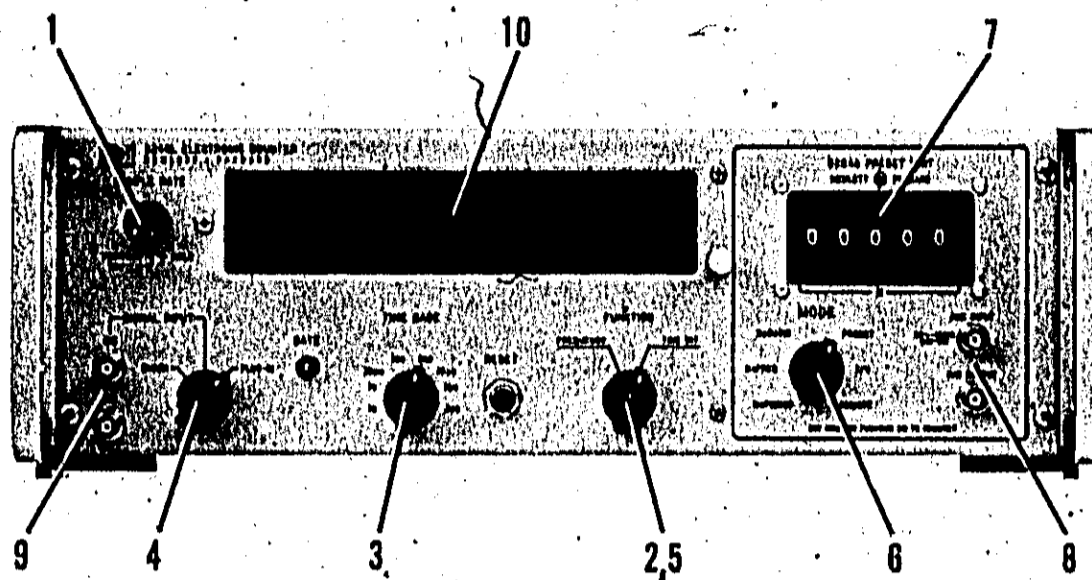

1. Turn Counter on with SAMPLE RATE control.
2. Set FUNCTION switch to FREQUENCY.
3. Set TIME BASE switch to desired time unit per count.
4. Set SIGNAL INPUT switch to CHECK to verify proper Counter operation.
5. Set Counter FUNCTION switch to TIME INT:
6. Set plug-in MODE switch to PRESET.
7. Set N switch for number of counts desired.
8. Connect a known signal (f_1) to plug-in AUX INPUT jack (10V max). (This is now the time base.)
9. Connect unknown signal (f_x) to Counter ac or dc input.
10. Display = $f_x/f_1 \times N$.

Figure 3-28. Model 5264A Operating Procedure PRESET

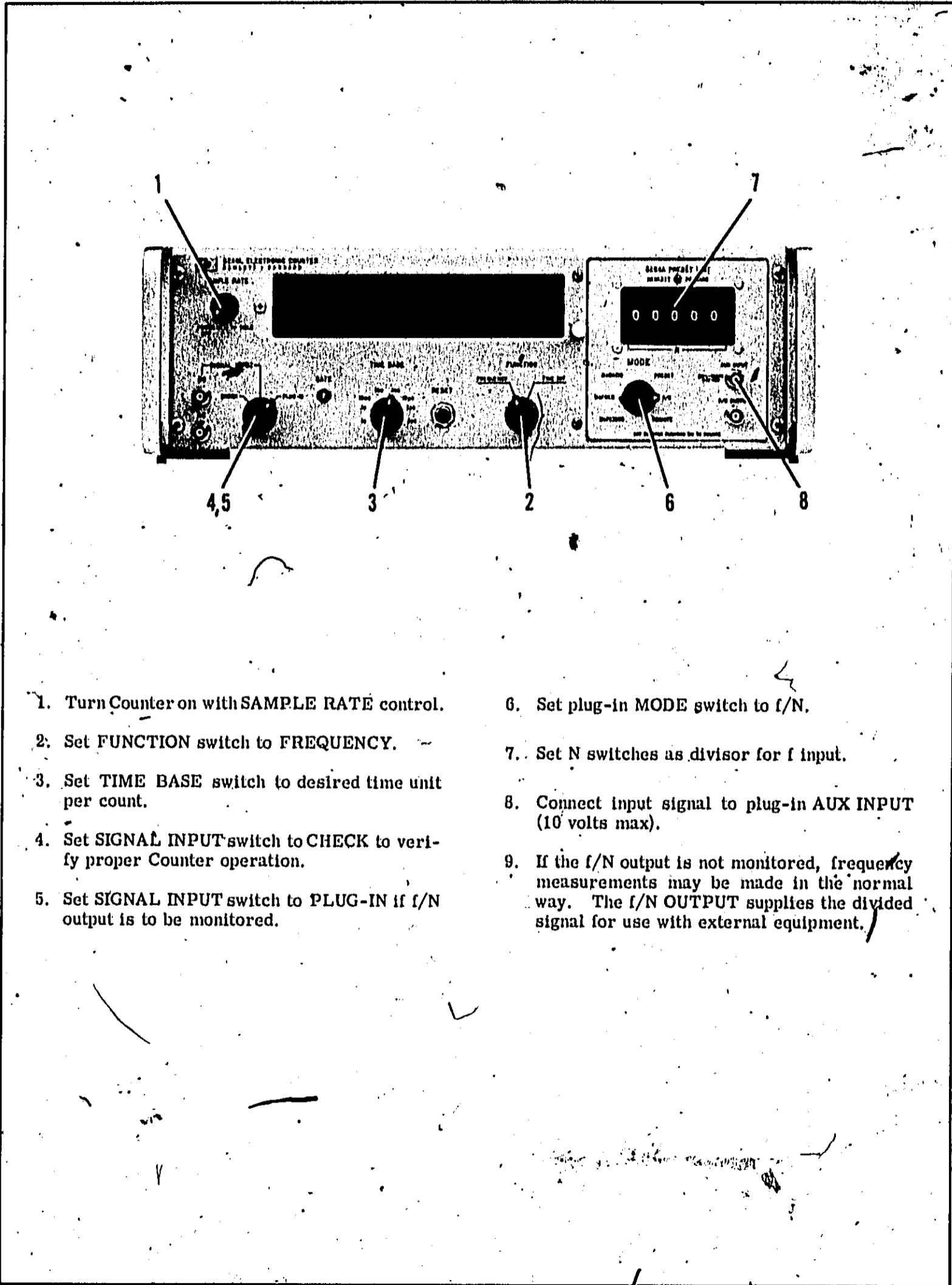

1. Turn Counter on with SAMPLE RATE control.
2. Set FUNCTION switch to FREQUENCY.
3. Set TIME BASE switch to desired time unit per count.
4. Set SIGNAL INPUT switch to CHECK to verify proper Counter operation.
5. Set SIGNAL INPUT switch to PLUG-IN if f/N output is to be monitored.
6. Set plug-in MODE switch to f/N.
7. Set N switches as divisor for f input.
8. Connect input signal to plug-in AUX INPUT (10 volts max).
9. If the f/N output is not monitored, frequency measurements may be made in the normal way. The f/N OUTPUT supplies the divided signal for use with external equipment.

Figure 3-29 Model 5264A Operating Procedure f/N

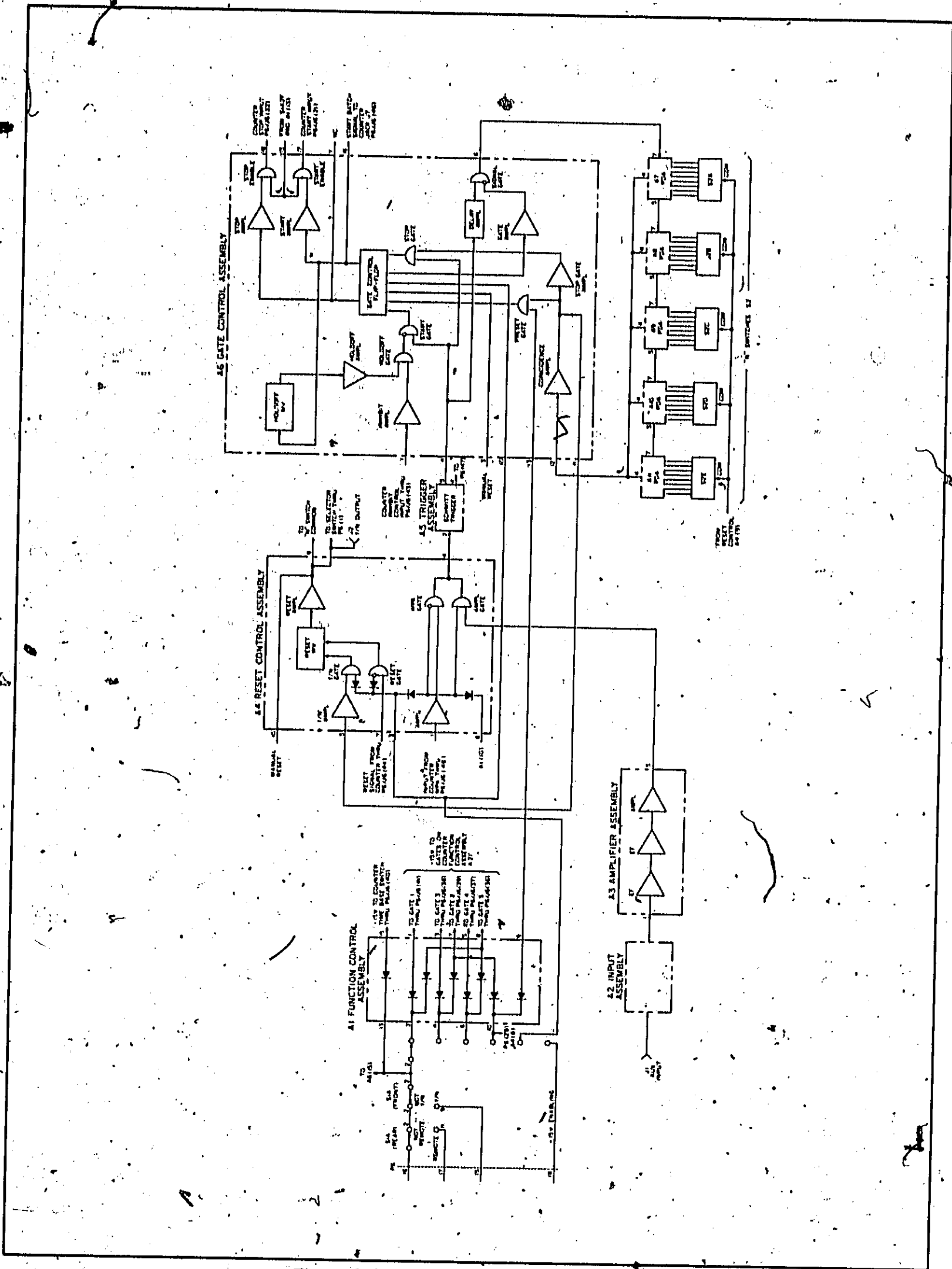

Figure 3-30. Model 5264A Block Diagram

3-133. 5265A DIGITAL VOLTMETER.

3-134. The following paragraphs contain information for operating the Model 5265A Digital Voltmeter plug-in when installed in the Model 5246L Electronic Counter.

3-135. The Model 5265A Digital Voltmeter provides DC voltage measurement capabilities for the Model 5246L Electronic Counter. DC voltages as high as 1000 volts can be measured on one of three ranges (10, 100, 1000). The plug-in unit VOLTS FULL SCALE switch selects the range. LOCAL or REMOTE operation is selected with the center red knob on the VOLTS FULL SCALE switch. Input DC voltage polarity is automatically indicated by the + or - neon. Over-range capability of the Voltmeter is +5% of the full-range voltage. Figure 3-32 shows the Model 5265A front-panel controls and indicators.

3-136. FRONT PANEL.

3-137. INPUT DC VOLTAGE CONNECTOR. Apply DC voltage of 0 to 1000 volts.

3-138. VOLTS FULL SCALE SWITCH. Selects correct range for the input DC voltage. Over-range capability is 5%.

3-139. LOCAL REMOTE SWITCH. Set to LOCAL for operation from Instrument or REMOTE for remote programming of voltmeter function.

3-140. ZERO ADJUST. Set VOLTS FULL SCALE switch to 1000 and adjust to 000000.00 on counter display.

3-141. CAL 8.000 ADJUSTMENT. Set VOLTS FULL SCALE switch to CAL 8.000 and adjust for 0008.0000 ±5 counts on counter display.

3-142. POLARITY INDICATORS. Neons automatically indicate polarity of input DC voltage.

3-143. DIGITAL VOLTMETER CALIBRATION.

3-144. For maximum operating accuracy, check ZERO and CAL 8.000 and set, if necessary. Set VOLTS FULL SCALE switch to 1000 and adjust ZERO control for 000000.00 and alternately flashing polarity neons. Set VOLTS FULL SCALE switch to CAL 8.000 position and adjust front panel screwdriver adjustment for 0008.0000, ±5 counts on the Counter display.

3-145. OPERATING PROCEDURE.

3-146. Figure 3-32 indicates an operating procedure for a dc voltage measurement with the Digital Voltmeter. Do not exceed the 5% over-range specification.

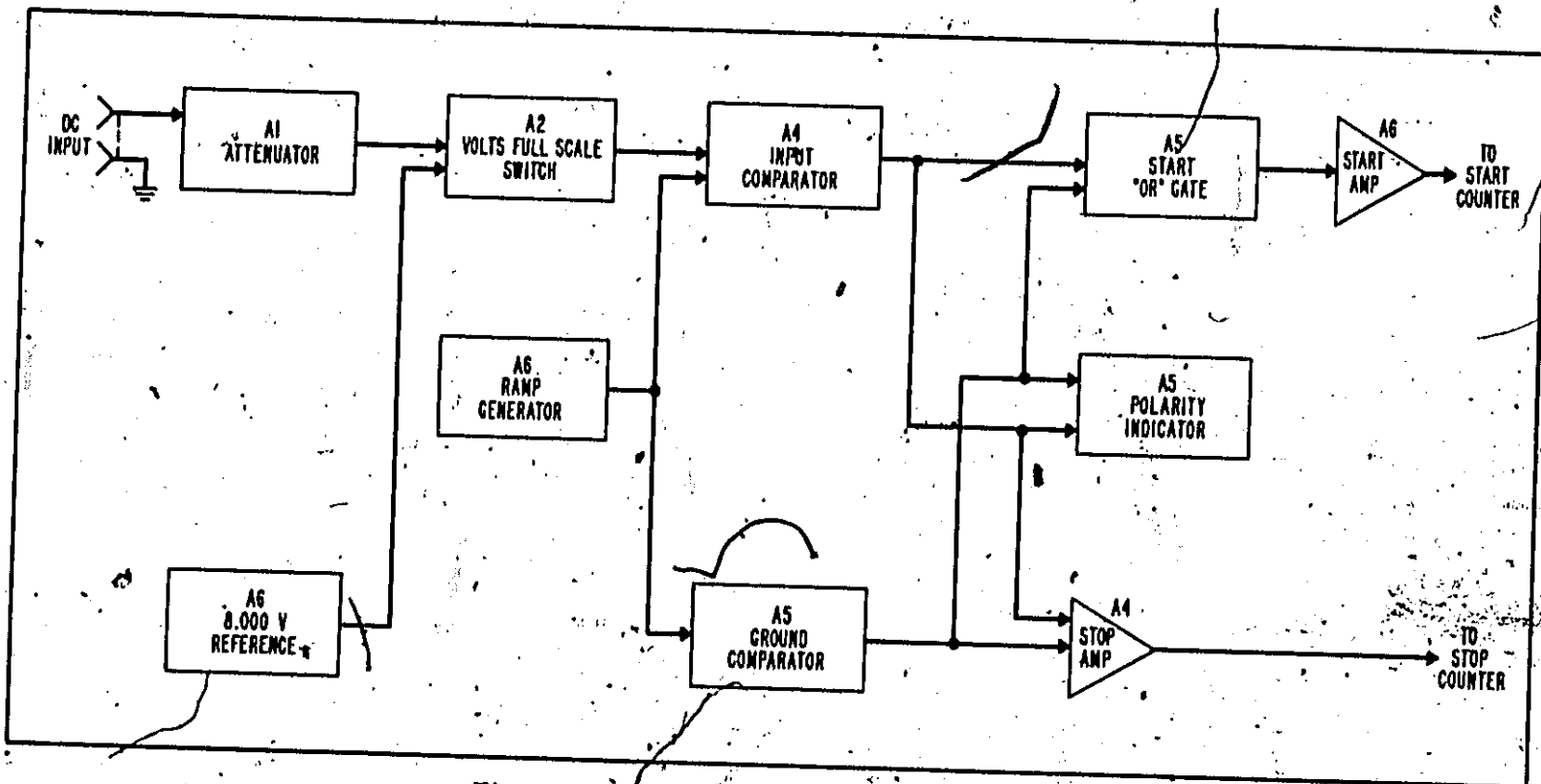
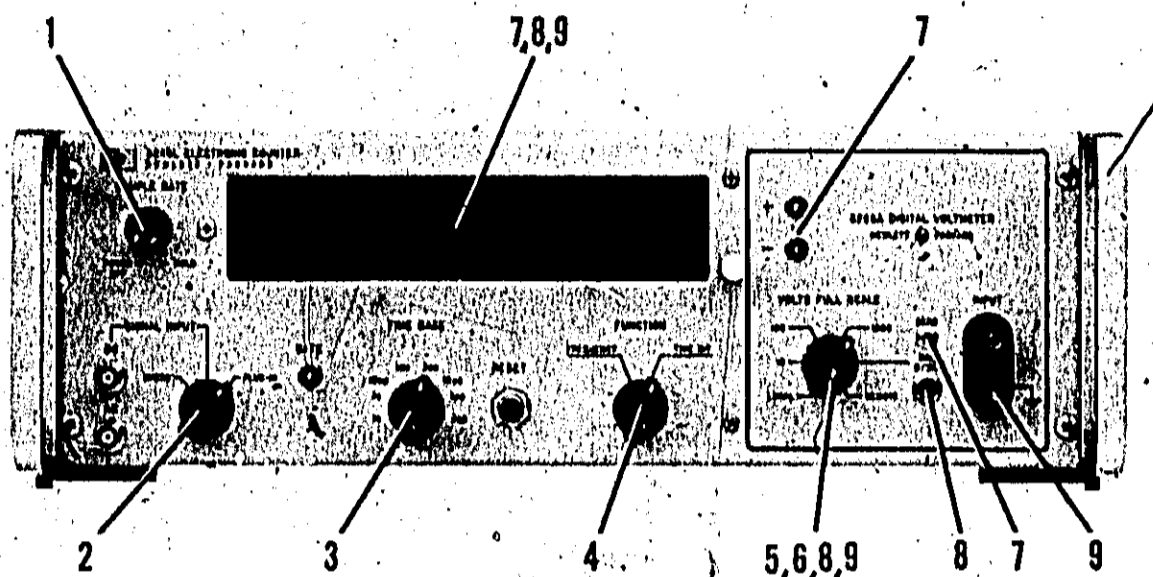

Figure 3-31. Model 5265A Block Diagram



1. Apply power to Counter and Voltmeter by turning SAMPLE RATE control clockwise to mid-position. Allow ten-minute warmup.
2. Set SIGNAL INPUT switch to a position other than CHECK.
3. Set TIME BASE to any position.
4. Set FUNCTION switch to TIME INTERVAL.
5. Set VOLTS FULL SCALE switch to 1000.
6. Set LOCAL-REMOTE switch to LOCAL.
7. Adjust ZERO control for display of 000000.00 and observe that polarity indicators alternately flash. Short INPUT terminals.
8. Set VOLTS FULL SCALE switch to CAL 8.000, and adjust CAL 8.000 control for 0008.0000 display, ± 5 counts. Remove short.
9. Set VOLTS FULL SCALE switch to 1000 and apply DC voltage at INPUT terminals. (If display indicates between 100 volts and 10 volts, switch Voltmeter to 100 range. If less than 10 volts, switch to 10 range.) Observe voltage magnitude on Counter display and voltage polarity as indicated by Voltmeter polarity neon.

Figure 3-32. Model 5265A Operating Procedure

SECTION IV MAINTENANCE

4-1. INTRODUCTION.

4-2. This section contains information for air filter care, fuse replacement, oscillator calibration, and a self-check table.

4-3. AIR FILTER.

4-4. Inspect the air filter (center of rear panel) regularly and clean it before it becomes dirty enough to restrict air flow. Proceed as follows:

- a. Remove top cover (unlock the two quarter turn fasteners and slide cover to the rear).
- b. Remove four screws holding filter in place.
- c. Wash filter in warm water and detergent.
- d. Allow filter to dry completely.

e. **DO NOT APPLY ANY COATING COMPOUND TO NON-METAL FILTERS.** Coat metal filters with light film of filter oil. We recommend No. 3 Filter Coat from Research Products Company. This adhesive is available in "Handi-Koter" sprayer cans at most heating supply stores or from your Hewlett-Packard Sales and Service Office.

4-5. FUSE REPLACEMENT.

4-6. Table 4-1 lists the fuse rating and Part No. for proper operation with either 115 Vac or 230 Vac.

4-7. OSCILLATOR CALIBRATION.

a. Connect Oscilloscope to FREQ STD BNC connector J4 on rear panel. Set EXT switch on rear panel to the INT position.

b. Set Counter SAMPLE RATE slightly clockwise out of POWER OFF.

c. Trigger Oscilloscope externally with a 100 kHz signal from a standard frequency source.

d. Set Oscilloscope sweep time to .1 μ s/cm. Adjust Oscilloscope controls to obtain a presentation of 3 volts peak-to-peak nonsinusoidal waveform.

e. Adjust Oscillator tuning capacitor C3 (Figure 4-1) until pattern on Oscilloscope stops drifting.

NOTE

With Oscilloscope sweep time in .1 μ s per cm position, drift of scope pattern of 1 cm in 1 second corresponds to accuracy of 1 part in 10^7 .

Table 4-1. Fuse Replacement

Conversion	115 Volt	230 Volt
Slide Switch	Left ("115")	Right ("230")
AC LINE FUSE	2 ampere slow-blow (ϕ 2110-0006)	1 ampere slow-blow (ϕ 2110-0007)

Table 4-2. Assembly Designations

A1	Input Switch Assembly (Sensitivity)
A2	Time Base Switch Assembly
A3	Function Switch Assembly
A4	Mode Switch Assembly
A5	Output Switch Assembly
A6	Rectifier Assembly
A7	Regulator Assembly
A8	Decimal Point Assembly
A9	Measurement Units Assembly
A10	Option 02
A11	Option 01
A12-A14	Low Frequency Decimal Counters
A15, A16	Medium Frequency Decimal Counters
A17	High Frequency Decimal Counter
A18	High Frequency Readout
A19, A20	Input Amplifier Assemblies
A21	Function Control Assembly
A22	Gate Control Assembly
A23	Sampling Control Assembly
A24, A25	Part of Option 06
A26	Oscillator Assembly
A27	Multiplier Assembly
A28	Medium Frequency Decade Divider
A29-A33	Low Frequency Decade Dividers

Table 4-3. Self Check

FUNCTION	TIME BASE	DISPLAYS	ASSEMBLIES CHECKED														GATES CHECKED																		
			2	10	11	12	13	14	15	16	27	28	29	30	31	32		33																	
Frequency	1 μ s	0000010. MHz	x								x	x																						3, 6, 12	
	10 μ s	0000010.0 MHz	x								x	x	x	x																				3, 6, 12	
	.1 ms	000010.00 MHz	x							x	x	x	x	x	x																			3, 6, 12	
	1 ms	00010000. kHz	x						x	x	x	x	x	x	x	x																		3, 6, 12	
	10 ms	0010000.0 kHz	x				x	x	x	x	x	x	x	x	x	x	x																		3, 6, 12
	.1 s	010000.00 kHz	x			x	x	x	x	x	x	x	x	x	x	x	x	x																	3, 6, 12
	1 s	10000.000 kHz	x	x	x	x	x	x	x	x	x	x	x	x	x	x	x	x	x																3, 6, 12

The following assemblies are checked in all positions used in the Self-Check Table: 6, 7, 17, 18, 21, 22, 23, and 26.

Assemblies 8 and 9 are checked in all Frequency Self-Checks.

The SIGNAL INPUT switch (A1) is in the check position for all Self-Check functions.

Assembly 19 is not checked in Self-Check functions.

Assembly 26 is checked for operation, but not for accuracy or stability.

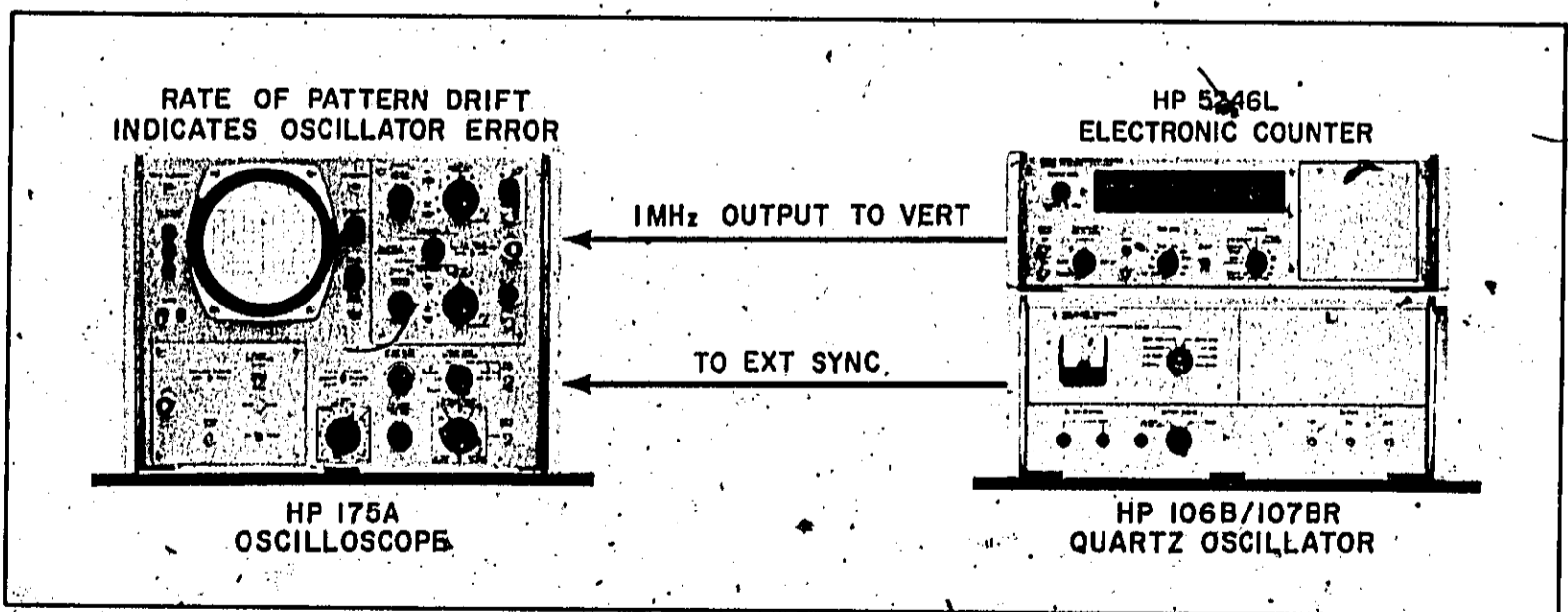

Figure 4-1. Test Setups for Checking Oscillator Frequency